

RUBBER COMPENSATORS

PURPOSE - ADVANTAGES

- To compensate axial, lateral and angular movements.
- To noise and vibration absorption.
- Shaped bead with hard rubber reinforcement ensures safety against slipping out of compensator flanges at terminal positions under conditions of alternating stress.



TYPES OF MOVEMENTS AND COMPENSATION CAPABILITY

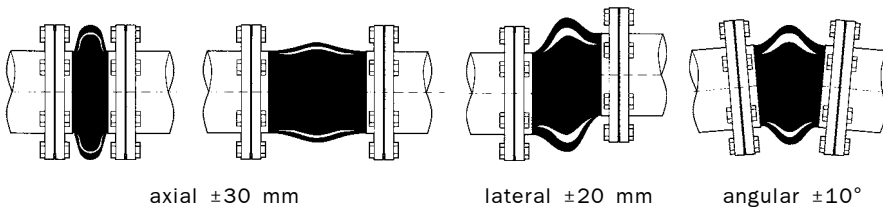

axial ±30 mm

lateral ±20 mm

angular ±10°

RUBBER BELLOWS, MEDIUMS, PRESSURES, TEMPERATURES, MARKING

Design /Material	Medium	Temperature [°C]		Colour Marking
		min.	max.	
1 / EPDM	supply water vapor up to +110 °C, outer influence of ozone	-40	110	no marking
2 / CIIR	dry or water containing subacid foodstuffs, alcohol	-25	70	double white
3 / NBR	oil product	-40	70	yellow

Max. working pressure [MPa/bar]	20 °C	50 °C	90 °C	110 °C
DN 40 - 150	1,6 / 16	1,6 / 16	1,0 / 10	0,8 / 8
DN 200 - 500	1,0 / 10	1,0 / 10	1,0 / 10	0,8 / 8

DIMENSIONS

DN	D ₁ [mm]	D ₂ [mm]	l [mm]	Counter Flanges [MPa/bar]	Weight [kg]
40	150	110	130	1,6 / 16	3,8
50	165	125	130	1,6 / 16	5,2
65	185	145	130	1,6 / 16	6,5
80	200	160	130	1,6 / 16	7,6
100	220	180	130	1,6 / 16	8,7
125	250	210	130	1,6 / 16	9,9
150	285	240	130	1,6 / 16	11,6
200	340	295	130	1,0 / 10	15,5
250	395	350	130	1,0 / 10	17,4
300	445	400	200	1,0 / 10	34,0
350	505	460	200	1,0 / 10	47,5
400	565	515	200	1,0 / 10	41,5
500	670	620	200	1,0 / 10	57,5

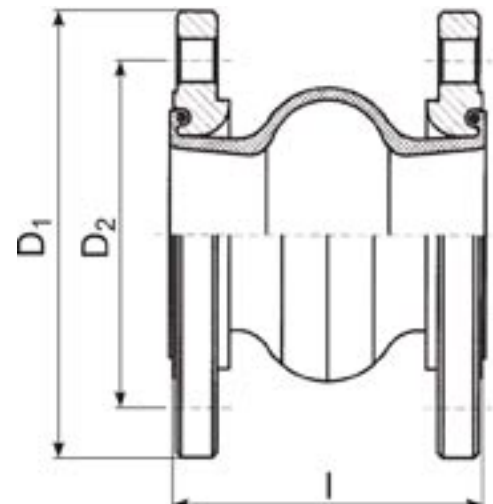

RUBENA a.s.
 ŠBU Speciální výroba
 Českých bratří 338
 547 36 Náchod
 Czech Republic

Tel.: +420 491 447 100
 Fax: +420 491 447 109
 E-mail: avs@rubena.cgs.cz
 E-shop: www.rubena.cz
 www.rubena.eu

 **Rubena**

Always Innovation