



Rubena

Dampers

Silentbloky

Амортизаторы

TRADICE / KVALITA / SPOLEHLIVOST

Přední evropský výrobce gumárenské produkce se 100-letou tradicí. Spolehlivost a vysoká kvalita vyráběné produkce odpovídá mezinárodním standardům certifikovaným společností SGS Zurich.

TRADITION / QUALITY / RELIABILITY

Leading European rubber manufacturer with 100-year tradition. Reliability and top quality of our products conform to international standards certified by SGS Zurich.

ТРАДИЦИЯ / КАЧЕСТВО / НАДЕЖНОСТЬ

Известный европейский производитель резиновых изделий со 100-летней традицией. Надежность и высокое качество выпускаемой продукции соответствует международным стандартам, сертифицированным обществом SGS Zurich.

2



CONTENTS / OBSAH / СОДЕРЖАНИЕ

GENERAL INFORMATION	6
Introduction / Logistics / New product / Vibration dampers Applied materials / Dimensional tolerances / Packaging / Storage Contacts list / Order example	
VŠEOBECNÉ INFORMACE	8
Úvod / Logistika / Nový výrobek / Silentbloky (Pružiny) Použité pryže / Rozměrové tolerance / Balení / Skladování Kontaktní adresa / Příklad objednávky	
ОБЩАЯ ИНФОРМАЦИЯ	10
Введение / Логистика / Новое изделие / Амортизаторы Использованные резины / Размерные допуски / Упаковка / ' ранение Список контактов / Пример заявки	
STANDARD VIBRATION DAMPERS	12
Typ 1, Typ 2, Typ 3, Typ 4, Typ 5 Load characteristics	44
VÁLCOVÉ PRUŽINY STANDARDNÍ	12
Typ 1, Typ 2, Typ 3, Typ 4, Typ 5 Zatěžovací charakteristiky	44
ЦИЛИНДРИЧЕСКИЕ АМОТИЗАТОРЫ - СТАНДАРТНЫЕ	12
Тип 1, Тип 2, Тип 3, Тип 4, Тип 5 Нагрузочные характеристики	44
CYLINDRICAL VIBRATION DAMPERS NONSTANDARD – FULL	48
Typ TP1, TP2, TP3, Typ SP, Typ KR	
VÁLCOVÉ PRUŽINY NESTANDARDNÍ - PLNÉ	48
Typ TP1, TP2, TP3, Typ SP, Typ KR	
ЦИЛИНДРИЧЕСКИЕ АМОТИЗАТОРЫ - НЕСТАНДАРТНЫЕ – МАССИВНЫЕ	48
Тип TP1, TP2, TP3, Тип SP, Тип KR	
CYLINDRICAL VIBRATION DAMPERS NONSTANDARD – PERFORMATED	50
Typ GH, Typ IS, Typ RB, Typ GK, Typ GP	
VÁLCOVÉ PRUŽINY NESTANDARDNÍ - PRŮCHOZÍ	50
Typ GH, Typ IS, Typ RB, Typ GK, Typ GP	
ЦИЛИНДРИЧЕСКИЕ АМОТИЗАТОРЫ - НЕСТАНДАРТНЫЕ - СКВОЗНЫЕ	50
Тип GH, Тип IS, Тип RB, Тип GK, Тип G	

<u>STOP DAMPERS – CIRCULAR</u>	<u>52</u>
Type KK, Type KP-D, KP-E, Type .16, Type DS, Type KD, Type KE, Type KH, Type KG	
<u>NÁRAZNÍKOVÉ PRUŽINY - KRUHOVÉ</u>	<u>52</u>
Typ KK, Typ KP-D, KP-E, Typ .16, Typ DS, Typ KD, Typ KE, Typ KH, Typ KG	
<u>БУФЕРЫ – КОНИЧЕСКИЕ</u>	<u>52</u>
Тип КК, Тип КР-D, КР-E, Тип .16, Тип DS, Тип КD, Тип КЕ, Тип КН, Тип КG	
<u>CYLINDRICAL VIBRATION DAMPERS NONSTANDARD - DISC</u>	<u>54</u>
<u>VÁLCOVÉ PRUŽINY NESTANDARDNÍ - KOTOUČOVÉ</u>	<u>54</u>
<u>ЦИЛИНДРИЧЕСКИЕ АМОТИЗАТОРЫ - НЕСТАНДАРТНЫЕ - ДИСКОВЫЕ</u>	<u>54</u>
<u>STOP DAMPERS – PRISMATIC</u>	<u>55</u>
Type TAB, Type RP – 0G, Type 01, Type KD	
<u>NÁRAZNÍKOVÉ PRUŽINY - HRANOLOVÉ</u>	<u>55</u>
Typ TAB, Typ RP - 0G, Typ .01, Typ KD	
<u>БУФЕРЫ – ПРИЗМАТИЧЕСКИЕ</u>	<u>55</u>
Тип ТАВ, Тип РР – 0G, Тип 01, Тип КD	
<u>STOP DAMPERS – GP</u>	<u>56</u>
ype GP – QP, Type GP – 1G, Type GP – 2G, Type GP – 1I	
<u>NÁRAZNÍKOVÉ PRUŽINY - GP</u>	<u>56</u>
Typ GP – QP, Typ GP – 1G, Typ GP – 2G, Typ GP – 1I	
<u>БУФЕРЫ – GP</u>	<u>56</u>
Тип GP – QP, Тип GP – 1G, Тип GP – 2G, Тип GP – 1I	
<u>COVER DAMPERS</u>	<u>57</u>
<u>POUZDROVÉ PRUŽINY</u>	<u>57</u>
<u>ВТУЛОЧНЫЕ АМОТИЗАТОРЫ</u>	<u>57</u>
<u>RUBBER-METAL RAILS</u>	<u>58</u>
<u>HRANOLOVÁ LŮŽKA</u>	<u>58</u>
<u>РЕЗИНО-МЕТАЛЛИЧЕСКИЕ ПРИЗМЫ</u>	<u>58</u>

HEAVY DUTY DAMPERS	59
VYSOKOZÁTĚŽOVÉ SILENTBLOKY	59
БУФЕРИ ДЛЯ ВЫСОКОХ НАГРУЗКИ	59
POLYURETHANE BUFFERS	61
POLYURETANOVÉ SILENTBLOKY	61
ПОЛИУРЕТАНОВЫЕ АМОРТИЗАТОРЫ	61



GENERAL INFORMATION VŠEOBECNÉ INFORMACE ОБЩАЯ ИНФОРМАЦИЯ

6 INTRODUCTION

RUBENA Inc. Hradec Králové belongs with its 100 years tradition to the oldest rubber works in Bohemia. The main productive activity comprises rubber and rubber-bonded metal parts. The company supplies its products into the automotive industry, mechanical engineering, building industry, electronics, defence of the State and sanitary engineering. You can meet our products in motor vehicles Škoda – VW, BMW, Peugeot, Renault, SEAT, Volvo, DAF, Tatra, LIAZ and in variety of other brands. Rubber parts with the company logo of RUBENA are present in assemblies, produced by Bosch, Siemens, Moulinex, Hella. You may find them in further final products, produced by many well-known companies.

LOGISTICS

Modern systems of production management and planning represent for RUBENA Inc. important tools in order to provide deliveries of quality products in time.

Our target is to always deliver the right quantity and qualities in the right time, according as require the plans of our customers.

By consistent monitoring each of our production processes we secure attainment of our objectives.

The manufacturing tradition, many years of development experience, competent co-operator team, adequate manufacturing equipment and a well-established system of production process quality management guarantee a "tailor-made" implementation of our customers requirements.

Our advantages are:

- product quality
- competitive prices
- short terms of delivery
- pre-sale servicing
- competent consultation
- deliveries up to the customer

NEW PRODUCT

When considering a new product we are prepared to offer you:

- cooperation for optimal solving of product shape,
- selection of most suitable material with respect to product end-use properties,
- development of a new compound according to a specific submission,
- elaboration of mould drawing documentation for the product using CAD/CAM systems,
- sample mould fabrication and delivery of sample mouldings,
- mould fabrication for rubber parts even of very complicated shapes.

VIBRATION DAMPERS

To the range of rubber and rubber-bonded metal parts belongs the commodity of VIBRATION DAMPERS.

RUBENA Inc. has been producing rubber-metal antivibration parts – dampers in the plant in Hradec Králové for more than 50 years.

They are intended for elastic mounting, shock damping, active and passive insulation of vibrations, noise absorbing, transfer of forces, protective mounting etc. High technology level and high variety of materials allows the production of high quality antivibration parts with required properties.

Modern technologies are applied for the production itself both in the area of metal parts preparation and in the area of moulding. To the basic materials, applied for the production, belong rubber grades based on NR and SBR. The product and process control are highly accentuated.

Our aim is to ensure trouble-free functionality and durability of manufactured parts and thereby a long-lasting satisfaction of our partners as well.

APPLIED MATERIALS

The vibration dampers are manufactured from elastomers based on NR, SBR and NBR with the standard hardness of 55 ShA, unless otherwise specified. For custom-made products it is possible to use materials within the range from 30 ShA to 85 ShA.

DIMENSIONAL TOLERANCES

Standard types are delivered with tolerance according to DIN 7715, part 2, Class M4 – see table below.

Dimension		Tolerance	F ±	C ±
	to 6.3	mm	0,5	0,5
from 6.3	to 10	mm	0,7	0,7
from 10	to 16	mm	0,8	0,8
from 16	to 25	mm	1,0	1,0
from 25	to 40	mm	1,3	1,3
from 40	to 63	mm	1,6	1,6
from 63	to 100	mm	2,0	2,0
from 100	to 160	mm	2,5	2,5
from 160		%	1,5	1,5

PACKAGING

The vibration dampers are dispatched in paper or PE bags, cardboard boxes or pallets. Only dampers of the same type and dimension are packed into one packing.

STORAGE

When the storage conditions according to ČSN 63 0001 are kept, the dampers may be stored for 7 years.

COMMERCIAL CONTACT - WHOLESALE WAREHOUSE

RUBENA a.s.
 Servisní sklad
 Českých bratří 338
 547 36 Nachod
 Czech Republic

Tel.: +420 491 447 558 – 9
 Tel.: +420 91 447 565 – 7
 Fax: +420 491 447 569
 E-mail: sklad@rubena.cgs.cz
 E-shop: www.rubena.cz

ORDER EXAMPLE

Cylindrical vibration damper, Type 2, 10/8 – M3x10 and number of pieces.
 Cylindrical vibration damper, Type 1, 10/10 – M4x10/M4x5 and number of pieces.
 Stop damper, Type – KD, 25/17 – M6x18 and number of pieces.

We shall be glad to inform you about the price, minimal ordering quantity and delivery date upon your inquiry.

VŠEOBECNÉ INFORMACE

8 ÚVOD

RUBENA a.s. Hradec Králové patří se stoletou tradicí výroby mezi nejstarší gumárenské podniky v Čechách. Hlavní náplní je výroba pryžových a pryžokovových dílů. Podnik dodává své výrobky pro automobilky, strojírenství, stavebnictví, elektroniku, obranu státu a zdravotnictví. S našimi výrobky se můžete setkat v automobilech Škoda - VW, BMW, Peugeot, Renault, SEAT, Volvo, DAF, Tatra, LIAZ a v řadě dalších značek. Pryžové díly s výrobním logem Rubena jsou i v kompletech firem Bosch, Siemens, Moulinex, Hella. Objevíte je i v řadě dalších finálních výrobků mnoha známých firem.

LOGISTIKA

Moderní systémy řízení výroby a plánování jsou pro Rubenu, a.s. důležité nástroje, aby mohla zajišťovat dodávky kvalitních výrobků včas. Naším cílem je vždy dodávat správné množství a kvalitu ve správné době, jak vyžadují plány našich zákazníků.

Trvalým monitorováním každého z našich výrobních procesů zajišťujeme dosažení našeho cíle.

Tradice výroby, dlouholeté zkušenosti z vývoje, kvalifikovaný tým spolupracovníků, odpovídající výrobní zařízení a zavedený systém řízení kvality výrobního procesu zaručují splnění požadavků každého zákazníka "na míru".

Naše přednosti jsou:

- kvalita výrobku,
- konkurenceschopné ceny,
- krátké dodací termíny,
- předprodejní servis,
- odborné konzultace,
- dodávky až k zákazníkovi.

NOVÝ VÝROBEK

Při zadávání požadavků na nový výrobek jsme připraveni vám nabídnout:

- spolupráci při optimálním řešení tvaru výrobku,
- výběr nejvhodnějšího materiálu s ohledem na užité vlastnosti výrobku,
- vývoj nové směsi podle specifického zadání,
- zpracování výkresové dokumentace formy na výrobek s použitím systémů CAD/CAM,
- vyrobení vzorkové formy a předání zkušebních výlisků,
- zhotovení forem na pryžové dílce i velmi komplikovaných tvarů.

SILENTBLOKY (PRUŽINY)

Součástí výroby pryžových a pryžokovových dílů je i komodita SILENTBLOKY.

Rubena a.s. vyrábí v provozu v Hradci Králové pryžokovové antivibrační prvky – silentbloky již více než 50 let. Jsou určeny k pružnému uložení, tlumení nárazů, aktivní i pasivní izolaci kmitů, hlukové izolaci, přenosu sil, ochrannému uložení a podobně. Vysoká úroveň technologie a široký sortiment používaných pryží umožňuje výrobu velmi kvalitních antivibračních dílů s požadovanými vlastnostmi.

Pro vlastní výrobu jsou aplikovány moderní technologie jak v oblasti přípravy kovových zálisků, tak v oblasti lisování. K základním materiálům používaným pro výrobu patří pryže na bázi NR a SBR. Velký důraz je kladen na kontrolu výrobků i výrobního procesu.

Naším cílem je zajistit bezproblémovou funkčnost a životnost námi vyráběných dílů a tím i dlouhodobou spokojenost našich partnerů.

POUŽITÉ PRYŽE

Silentbloky jsou vyráběny z pryží na bázi NR, SBR a NBR v standardní tvrdosti 55 ShA, pokud není uvedeno jinak. Na zakázku lze použít pryže v rozmezí od 30 do 85 ShA.

ROZMĚROVÉ TOLERANCE

U standardního provedení se silentbloky dodávají s tolerancí dle DIN 7715 díl 2, Třída M4 - viz tabulka.

Rozměr		Tolerance	F ±	C ±
	od 6,3	mm	0,5	0,5
od 6,3	do 10	mm	0,7	0,7
od 10	do 16	mm	0,8	0,8
od 16	do 25	mm	1,0	1,0
od 25	do 40	mm	1,3	1,3
od 40	do 63	mm	1,6	1,6
od 63	do 100	mm	2,0	2,0
od 100	do 160	mm	2,5	2,5
od 160		%	1,5	1,5

BALENÍ

Silentbloky se expedují v papírových nebo PE sáčcích, kartónových krabicích nebo paletách. Do jednoho obalu se balí silentbloky jen jednoho druhu a rozměru.

SKLADOVÁNÍ

Při dodržení skladovacích podmínek dle ČSN 63 0001, lze skladovat silentbloky 7 let.

OBCHODNÍ SPOJENÍ - SERVISNÍ SKLAD

RUBENA a.s. Hradec Králové

Servisní sklad

Českých bratří 338

547 36 Náchod

Česká republika

tel.: 491 447 558 – 9

tel.: 491 447 565 – 7

fax: 491 447 569

e-mail: sklad@rubena.cgs.cz

e-shop: www.rubena.cz

PŘÍKLAD OBJEDNÁVKY

Válcová pružina, Typ 2, 10/8 - M3x10 a počet kusů.

Válcová pružina, Typ 1, 10/10 - M4x10/M4x5 a počet kusů.

Nárazníková pružina, Typ - KD, 25/17 - M6x18 a počet kusů.

Cenu, minimální objednávací množství a termín dodání vám rádi sdělíme na základě konkrétní poptávky.

ОБЩАЯ ИНФОРМАЦИЯ

10 ВВЕДЕНИЕ

АО «RUBENA» ГрадецКралове принадлежит с ее столетней традицией к самым старшим резиновым заводам в Чехии. Основной производственной деятельностью является производство резиновых и резино-металлических изделий. Завод поставляет свои изделия на автозаводы, фирмам из отрасли машиностроения, строительства, электроники, государственной обороны и здравоохранения. Изделия фирмы «RUBENA» применяются в автомобилях Škoda - VW, BMW, Peugeot, Renault, SEAT, Volvo, DAF, Tatra, LIAZ и ряду других марок. Резиновые детали с эмблемой «RUBENA» находятся в комплектах фирм Bosch, Siemens, Moulinex, Hella и возможно их найти в ряду готовых изделий производства многих знакомых компаний.

ЛОГИСТИКА

Современные системы управления производства и планировки являются для фирмы «RUBENA» немаловажными инструментами, чтобы было возможно обеспечивать доставки качественных изделий вовремя.

Нашей целью является всегда поставлять правильное количество и качество в правильное время, как требуют планы наших заказчиков.

Постоянным наблюдением каждого из наших производственных процессов обеспечиваем достижение нашей цели.

Традиция производства, многолетний опыт из развития, квалифицированный коллектив сотрудников, соответствующее производное оборудование и освоенная система управления качества производного процесса гарантируют аккуратное выполнение требований каждого заказчика.

Нашими преимуществами являются:

- качество изделия
- конкурентоспособные цены
- короткие сроки поставки
- предпродажный сервис
- профессиональные консультации
- поставки прямо к заказчику

НОВОЕ ИЗДЕЛИЕ

При обсуждению требований на новое изделие мы готовы предложить вам:

- сотрудничество для оптимального решения конфигурации изделия,
- выбор наиболее подходящего материала, учитывая полезные свойства изделия,
- разработка новой смеси по специфическому заданию,
- выработка чертежной документации пресс-формы для изделия с использованием систем CAD/CAM,
- изготовление испытательной пресс-формы и передача испытательных образцов,
- изготовление пресс-форм для резиновых деталей даже и с очень сложным фасоном.

АМОРТИЗАТОРЫ

Составной частью резиновых и резино-металлических изделий является также товарная группа АМОРТИЗАТОРЫ.

АО «RUBENA» выпускает на заводе в г. Градец Кралове резино-металлические антивибрационные компоненты - амортизаторы уже свыше 50 лет. Они предназначены для упругой установки, затухания набросов, активной и пассивной изоляции колебаний, шумовой изоляции, передачи сил, защитной установки и т. п. Высокий уровень технологии и широкий ассортимент использованных резиновых смесей позволяет изготовление высококачественных антивибрационных компонентов требуемых свойств.

В процессе производства применяются современные технологии как в области подготовки металлических арматуры, так и в области прессования. К основным использованным для производства материалам принадлежат резины на основе NR и SBR. Особое значение имеет контроль изделий и производственного процесса.

Нашей целью является обеспечение безпроблемной функциональности и срока службы выпускаемых нами изделий и тем также долговременное удовольствие наших партнеров.

ИСПОЛЬЗОВАННЫЕ РЕЗИНЫ

Амортизаторы изготавливаются из резин на основе NR, SBR и NBR со стандартной твердостью 55 ftor A, если не установлено иначе. По заказу возможно использовать резины твердостью в пределах от 30 до 85 ftor A.

РАЗМЕРНЫЕ ДОПУСКИ

Стандартные модели (типы) амортизаторов поставляются с размерными допусками согласно DIN 7715, часть 2, класс M4 – см. таблицу.

Размер		Допуск	F ±	C ±
	до 6.3	mm	0,5	0,5
от 6.3	до 10	mm	0,7	0,7
от 10	до 16	mm	0,8	0,8
от 16	до 25	mm	1,0	1,0
от 25	до 40	mm	1,3	1,3
от 40	до 63	mm	1,6	1,6
от 63	до 100	mm	2,0	2,0
от 100	до 160	mm	2,5	2,5
от 160		%	1,5	1,5

УПАКОВКА

Амортизаторы отправляются в бумажных или полиэтиленовых мешках, картонных коробках или поддонах. В одной упаковке отправляются только амортизаторы одного типа и размера.

УХРАНЕНИЕ

При соблюдении условий хранения согласно ČSN 63 0001, возможно хранить амортизаторы 7 лет.

ДЕЛОВЫЕ КОНТАКТЫ - ОПТОВЫЙ СКЛАД

RUBENA a.s.
 Servisní sklad
 Českých bratří 338
 547 36 Nachod
 Czech Republic

Тел.: +420 491 447 559
 Факс: +420 491 447 569
 E-mail: sklad@rubena.cgs.cz
 E-shop: www.rubena.cz

ПРИМЕР ЗАЯВКИ

Цилиндрический амортизатор, Тип 2, 10/8 – M3x10 и количество штук.
 Цилиндрический амортизатор, Тип 1, 10/10 – M4x10/M4x5 и количество штук.
 Буфер, Тип – KD, 25/17 – M6x18 и количество штук.

Цену, минимальное количество и срок поставки рады сообщим на основе конкретного запроса.

STANDARD VIBRATION DAMPERS
 VÁLCOVÉ PRUŽINY STANDARDNÍ
 ЦИЛИНДРИЧЕСКИЕ АМОРТИЗАТОРЫ - СТАНДАРТНЫЕ

Type 1

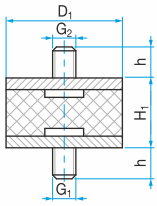

Type 2

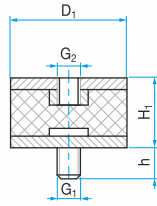

Type 3

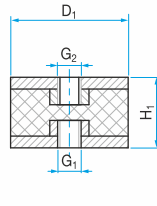

Type 4

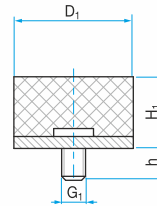

Type 5

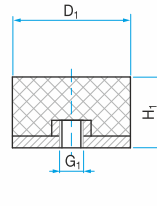

D ₁	H ₁	Thread 1 Závit 1 Винт 1 (Gxh)	Thread 2 Závit 2 Винт 2 (Gxh)	ShA ftop A	Shape Tvar Модель	Type Typ Тип
6	7	M 3x6	-	55	-	1
6	7	M 3x6	M 3x3	55	-	1
6	7	M 3x10	-	55	-	1
6	7	M 3x4	-	55	-	2
6	7	M 3x6	-	55	-	2
6	7	M 3	-	55	-	3
6	7	M 3x6	-	55	-	4
6	13	M 3x6	-	55	-	1
8	5	M 3x4	-	55	-	1
8	5	M 3x6	-	55	-	4
8	6	M 3x6	-	55	-	1
8	6	M 3x6	M 3x3	55	-	1
8	6	M 3x6	-	55	-	2
8	6	M 4x6	-	55	-	2
8	6	M 3x6	-	55	-	4
8	6	M 4x6	-	55	-	4
8	6	M 4x10	-	55	-	4
8	8	M 3x4	-	55	-	1
8	8	M 3x6	-	55	-	1
8	8	M 3x10	-	55	-	1
8	8	M 3x15	-	55	-	1
8	8	M 3x3	-	55	-	2
8	8	M 3x5	-	55	-	2
8	8	M 3x6	-	55	-	2
8	8	M 3x8	-	55	-	2
8	8	M 3x10	-	55	-	2
8	8	M 4x5	-	55	-	2
8	8	M 4x6	-	55	-	2
8	8	M 4x10	-	55	-	2
8	8	M 3	-	55	-	3
8	8	M 3x4	-	55	-	4
8	8	M 3x6	-	55	-	4
8	8	M 3	-	55	-	5
8	10	M 3x6	-	55	-	1
8	10	M 3x6	-	55	-	2
8	10	M 3	-	55	-	3
8	13	M 3x4	-	55	-	2
8	13	M 3x6	-	55	-	2
8	13	M 3	-	55	-	5
8	15	M 3x4	-	55	-	2
8	15	M 3x6	-	55	-	2
8	15	M 3	-	55	-	3
9	7	M 4x12	-	55	-	4

D ₁	H ₁	Thread 1 Závit 1 Винт 1 (Gxh)	Thread 2 Závit 2 Винт 2 (Gxh)	ShA ftop A	Shape Tvar Модель	Type Typ Тип
9	12	M 4x6	-	55	-	1
9	12	M 4x12	-	55	-	1
9	12	M 4x12	-	55	-	4
9	12	M 4	-	55	-	5
10	5	M 4x10	-	55	-	1
10	5	M 4x6	-	55	-	4
10	5	M 5x10	-	55	-	4
10	6	M 3x6	-	55	-	1
10	6	M 4x6	-	55	-	1
10	6	M 4x10	-	55	-	1
10	6	M 3x6	-	55	-	4
10	6	M 4x6	-	55	-	4
10	6	M 4x10	-	55	-	4
10	6	M 4x15	-	55	-	4
10	8	M 3x6	-	55	-	1
10	8	M 3x9	-	55	-	1
10	8	M 4x6	-	55	-	1
10	8	M 4x10	-	55	-	1
10	8	M 3x3	-	55	-	2
10	8	M 3x6	-	55	-	2
10	8	M 3x10	-	55	-	2
10	8	M 4x4	-	55	-	2
10	8	M 4x5	-	55	-	2
10	8	M 4x6	-	55	-	2
10	8	M 4x10	-	55	-	2
10	8	M 4	-	55	-	3
10	8	M 3x6	-	55	-	4
10	8	M 4x6	-	55	-	4
10	8	M 4x8	-	55	-	4
10	8	M 4x10	-	55	-	4
10	8	M 4x12	-	55	-	4
10	8	M 4x15	-	55	-	4
10	8	M 5x12	-	55	-	4
10	8	M 4	-	55	-	5
10	10	M 3x6	-	55	-	1
10	10	M 4x5	-	55	-	1
10	10	M 4x6	-	55	-	1
10	10	M 4x8	-	55	-	1
10	10	M 4x10	-	55	-	1
10	10	M 4x10	M 4x5	55	-	1
10	10	M 4x10	M 4x6	55	-	1
10	10	M 3x4	-	55	-	2
10	10	M 3x6	-	55	-	2

Note: Thread 2 = Thread 1 unless otherwise specified. / Poznámka: Závit 2 = Závit 1 pokud není uvedeno jinak. / Заметка: Винт 2 = Винт 1, если не установлено иначе.

Type 1



Type 2



Type 3



Type 4



Type 5



D ₁	H ₁	Thread 1 Závit 1 Винт 1 (Gxh)	Thread 2 Závit 2 Винт 2 (Gxh)	ShA ftop A	Shape Tvar Модель	Type Typ Тип
10	10	M 3x10	-	55	-	2
10	10	M 4x4	-	55	-	2
10	10	M 4x5	-	55	-	2
10	10	M 4x6	-	55	-	2
10	10	M 4x8	-	55	-	2
10	10	M 4x9	-	55	-	2
10	10	M 4x10	-	55	-	2
10	10	M 4x12	-	55	-	2
10	10	M 3	-	55	-	3
10	10	M 4	-	55	-	3
10	10	M 4x6	-	55	-	4
10	10	M 4x8	-	55	-	4
10	10	M 4x10	-	55	-	4
10	10	M 4x13	-	55	-	4
10	10	M 5x10	-	55	-	4
10	10	M 4	-	55	-	5
10	15	M 4x4	-	55	-	1
10	15	M 4x10	-	55	-	1
10	15	M 4x12	-	55	-	1
10	15	M 4x15	-	55	-	1
10	15	M 5x5	-	55	-	1
10	15	M 5x10	-	55	-	1
10	15	M 5x12	-	55	-	1
10	15	M 3x10	-	55	-	2
10	15	M 4x6	-	55	-	2
10	15	M 4x10	-	55	-	2
10	15	M 5x5	-	55	-	2
10	15	M 5x6	-	55	-	2
10	15	M 5x10	-	55	-	2
10	15	M 5x12	M 4	55	-	2
10	15	M 3	-	55	-	3
10	15	M 4	-	55	-	3
10	15	M 5	-	55	-	3
10	15	M 4x8	-	55	-	4
10	15	M 4x10	-	55	-	4
10	15	M 4x15	-	55	-	4
10	15	M 5x10	-	55	-	4
10	15	M 5x12	-	55	-	4
10	15	M 4	-	55	-	5
10	17	M 4x10	-	55	-	1
10	17	M 3x3	-	55	-	2
10	17	M 3x6	-	55	-	2
10	17	M 4x10	-	55	-	2

D ₁	H ₁	Thread 1 Závit 1 Винт 1 (Gxh)	Thread 2 Závit 2 Винт 2 (Gxh)	ShA ft op A	Shape Tvar Модель	Type Typ Тип
10	18	M 4x6	-	55	-	1
10	18	M 4x13	-	55	-	1
10	18	M 3	-	55	-	3
10	18	M 4	-	55	-	3
10	18	M 5	-	55	-	3
10	18	M 4	-	55	-	5
10	30	M 4x10	-	55	-	1
10	18	M 4x6	-	55	-	1
10	18	M 4x13	-	55	-	1
10	18	M 3	-	55	-	3
10	18	M 4	-	55	-	3
10	18	M 5	-	55	-	3
10	18	M 4	-	55	-	5
10	30	M 4x10	-	55	-	1
10	30	M 4x 6	-	55	-	2
11	11	M 4x10	-	55	-	1
11	11	M 4x10	-	55	-	2
11	11	M 4	-	55	-	3
11	11	M 4	-	55	-	5
12	5	M 5x12	-	55	-	4
12	6,5	M 5x 6	-	55	-	1
12	6,5	M 5x 6	-	55	-	4
12	6,5	M 5x10	-	55	-	4
12	7	M 4x10	-	55	-	4
12	10	M 4x 8	-	55	-	1
12	10	M 5x 8	-	55	-	1
12	10	M 5x10	-	55	-	1
12	10	M 5x12	-	55	-	1
12	10	M 4x 8	-	55	-	2
12	10	M 4x10	-	55	-	2
12	10	M 5x13	-	55	-	2
12	10	M 5x10	-	55	-	4
12	10	M 5x12	-	55	-	4
12	10	M 5	-	55	-	5
12	15	M 4x10	-	50	51.12	1
12	19	M 5x13	-	55	-	1
13	10	M 4x10	-	55	-	4
13	10	M 5x10	-	55	-	4
13	15	M 5x10	-	55	-	1
13	15	M 5x10	-	55	-	2
13	8	M 4x 9	-	55	-	1
13	13	M 6	-	55	-	5
13	20	M 4x12	-	55	-	1

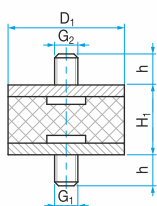
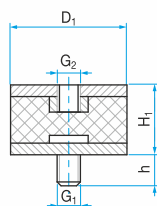
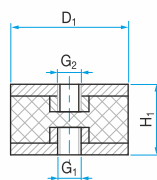
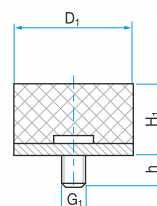
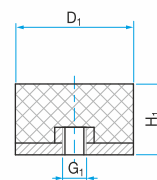
Type 1

Type 2

Type 3

Type 4

Type 5

14

D ₁	H ₁	Thread 1 Závít 1 Винт 1 (Gxh)	Thread 2 Závít 2 Винт 2 (Gxh)	ShA ftop A	Shape Tvar Модель	Type Typ Тип
13	26	M 4x 6	-	55	-	1
13	26	M 4x10	-	55	-	1
13	26	M 4	-	55	-	3
13	26	M 4	-	55	-	5
15	4	M 4x 8	-	55	-	1
15	4	M 4x 6	-	55	-	4
15	4	M 4x 7	-	55	-	4
15	4	M 4x 8	-	55	-	4
15	4	M 4x10	-	55	-	4
15	4	M 5x18	-	55	-	4
15	5	M 4x10	-	55	-	1
15	5	M 6x10	M 6x 6	55	-	1
15	5	M 6x15	M 6x 6	55	-	1
15	5	M 4x 6	-	55	-	4
15	5	M 4x 8	-	55	-	4
15	5	M 4x15	-	55	-	4
15	6	M 4x 8	-	55	-	1
15	6	M 4x10	-	55	-	1
15	6	M 6x10	-	55	-	1
15	6	M 4x 5	-	55	-	4
15	6	M 4x 6	-	55	-	4
15	6	M 4x 7	-	55	-	4
15	6	M 4x 8	-	55	-	4
15	6	M 4x10	-	55	-	4
15	6	M 4x12	-	55	-	4
15	6	M 4x13	-	55	-	4
15	6	M 4x15	-	55	-	4
15	6	M 6x 8	-	55	-	4
15	6	M 6x10	-	55	-	4
15	6	M 4	-	55	-	5
15	7	M 4x10	-	55	-	1
15	7	M 4x 6	-	55	-	4
15	7	M 4x10	-	55	-	4
15	7	M 5x12	-	55	-	4
15	7	M 6x16	-	55	-	4
15	7	M 6x20	-	55	-	4
15	7	M 6x26	-	55	-	4
15	7,5	M 6x16	-	55	-	4
15	8	M 4x 5	-	55	-	1
15	8	M 4x 6	-	55	-	1
15	8	M 4x 8	-	55	-	1
15	8	M 4x10	-	55	-	1
15	8	M 4x13	-	55	-	1

D ₁	H ₁	Thread 1 Závít 1 Винт 1 (Gxh)	Thread 2 Závít 2 Винт 2 (Gxh)	ShA ftop A	Shape Tvar Модель	Type Typ Тип
15	8	M 5x 8	-	55	-	1
15	8	M 5x10	-	55	-	1
15	8	M 5x15	-	55	-	1
15	8	M 3x 4	-	55	-	2
15	8	M 4x 6	-	55	-	2
15	8	M 4x10	-	55	-	2
15	8	M 4x 5	-	55	-	4
15	8	M 4x 6	-	55	-	4
15	8	M 4x 8	-	55	-	4
15	8	M 4x10	-	55	-	4
15	8	M 4x12	-	55	-	4
15	8	M 4x13	-	55	-	4
15	8	M 4x15	-	55	-	4
15	8	M 4x18	-	55	-	4
15	8	M 5x10	-	55	-	4
15	8	M 5x12	-	55	-	4
15	8	M 5x15	-	55	-	4
15	8	M 6x 8	-	55	-	4
15	8	M 8x55	-	55	-	4
15	8	M 3	-	55	-	5
15	8	M 4	-	55	-	5
15	9	M 5x12	-	55	-	1
15	9	M 5x 8	-	55	-	4
15	9	M 5x12	-	55	-	4
15	9	M 5	-	55	-	5
15	10	M 4x10	-	55	-	1
15	10	M 5x 8	-	55	-	1
15	10	M 5x10	-	55	-	1
15	10	M 5x12	-	55	-	1
15	10	M 6x 8	-	55	-	1
15	10	M 6x10	-	55	-	1
15	10	M 8x20	-	55	-	1
15	10	M 3x 6	-	55	-	2
15	10	M 4x 8	-	55	-	2
15	10	M 4x10	-	55	-	2
15	10	M 4x13	-	55	-	2
15	10	M 5x 4	-	55	-	2
15	10	M 5x 8	-	55	-	2
15	10	M 5x10	-	55	-	2
15	10	M 5x13	-	55	-	2
15	10	M 6x18	-	55	-	2
15	10	M 4	-	55	-	3
15	10	M 5	-	55	-	3

Note: Thread 2 = Thread 1 unless otherwise specified. / Poznámka: Závít 2 = Závít 1 pokud není uvedeno jinak. / Заметка: Винт 2 = Винт 1, если не установлено иначе.

Type 1



Type 2



Type 3



Type 4



Type 5



D ₁	H ₁	Thread 1 Závit 1 Винт 1 (Gxh)	Thread 2 Závit 2 Винт 2 (Gxh)	ShA ftop A	Shape Tvar Модель	Type Typ Тип
15	10	M 4x 8	-	55	-	4
15	10	M 4x10	-	55	-	4
15	10	M 4x13	-	55	-	4
15	10	M 5x 8	-	55	-	4
15	10	M 5x10	-	55	-	4
15	10	M 5x12	-	55	-	4
15	10	M 5x15	-	55	-	4
15	10	M 5x28	-	55	-	4
15	10	M 6x 6	-	55	-	4
15	10	M 6x12	-	55	-	4
15	10	M 6x15	-	55	-	4
15	10	M 6x18	-	55	-	4
15	10	M 6x23	-	55	-	4
15	10	M 6x25	-	55	-	4
15	10	M 6x28	-	55	-	4
15	10	M 4	-	55	-	5
15	10	M 8	-	55	-	5
15	12	M 4x 8	-	55	-	1
15	12	M 4x 6	-	55	-	2
15	12	M 4x13	-	55	-	2
15	12	M 4x 8	-	55	-	4
15	12	M 4x12	-	55	-	4
15	12	M 4	-	55	-	5
15	13	M 3x 6	-	55	-	1
15	13	M 4x10	-	55	-	1
15	13	M 4x15	-	55	-	1
15	13	M 4x10	-	55	-	2
15	13	M 6x20	-	55	-	2
15	13	M 4x 5	-	55	-	4
15	13	M 4x 8	-	55	-	4
15	13	M 4x10	-	55	-	4
15	13	M 4x13	-	55	-	4
15	13	M 4x15	-	55	-	4
15	13	M 5x10	-	55	-	4
15	13	M 6x12	-	55	-	4
15	13	M 4	-	55	-	5
15	15	M 4x 5	M 4x 8	55	-	1
15	15	M 4x 6	-	55	-	1
15	15	M 4x 6	M 4x 8	55	-	1
15	15	M 4x 8	-	55	-	1
15	15	M 4x10	-	55	-	1
15	15	M 4x12	-	55	-	1
15	15	M 4x12	M 5x15	55	-	1

D ₁	H ₁	Thread 1 Závit 1 Винт 1 (Gxh)	Thread 2 Závit 2 Винт 2 (Gxh)	ShA ft op A	Shape Tvar Модель	Type Typ Тип
15	15	M 4x13	-	55	-	1
15	15	M 4x14	-	55	-	1
15	15	M 4x15	-	55	-	1
15	15	M 4x18	-	55	-	1
15	15	M 4x19	-	55	-	1
15	15	M 5x 8	-	55	-	1
15	15	M 5x10	-	55	-	1
15	15	M 5x12	-	55	-	1
15	15	M 5x13	-	55	-	1
15	15	M 5x15	-	55	-	1
15	15	M 5x15	M 5x10	55	-	1
15	15	M 5x22	-	55	-	1
15	15	M 6x10	-	55	-	1
15	15	M 6x12	-	55	-	1
15	15	M 6x15	-	55	-	1
15	15	M 6x15	M 6x 5	55	-	1
15	15	M 6x18	-	55	-	1
15	15	M 3x 6	-	55	-	2
15	15	M 3x10	-	55	-	2
15	15	M 4x 5	-	55	-	2
15	15	M 4x 6	-	55	-	2
15	15	M 4x 8	-	55	-	2
15	15	M 4x10	-	55	-	2
15	15	M 4x12	-	55	-	2
15	15	M 4x13	-	55	-	2
15	15	M 4x14	-	55	-	2
15	15	M 4x15	-	55	-	2
15	15	M 4x19	-	55	-	2
15	15	M 5x 5	-	55	-	2
15	15	M 5x 6	-	55	-	2
15	15	M 5x 8	-	55	-	2
15	15	M 5x10	-	55	-	2
15	15	M 5x11	-	55	-	2
15	15	M 5x12	-	55	-	2
15	15	M 5x13	-	55	-	2
15	15	M 5x15	-	55	-	2
15	15	M 6x10	-	55	-	2
15	15	M 6x12	-	55	-	2
15	15	M 6x15	-	55	-	2
15	15	M 3	-	55	-	3
15	15	M 4	-	55	-	3
15	15	M 5	-	55	-	3
15	15	M 6	-	55	-	3

Type 1

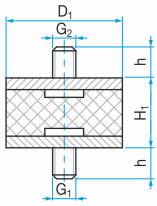

Type 2

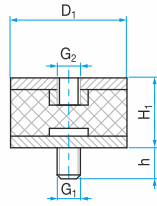

Type 3

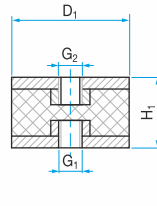

Type 4

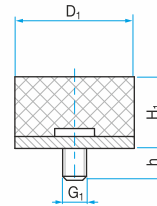

Type 5

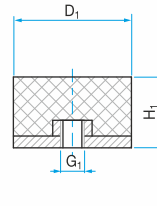

D ₁	H ₁	Thread 1 Závit 1 Винт 1 (Gxh)	Thread 2 Závit 2 Винт 2 (Gxh)	ShA ftop A	Shape Tvar Модель	Type Typ Тип
15	15	M 4x 8	-	55	-	4
15	15	M 4x10	-	55	-	4
15	15	M 4x12	-	55	-	4
15	15	M 4x13	-	55	-	4
15	15	M 4x15	-	55	-	4
15	15	M 4x23	-	55	-	4
15	15	M 5x 8	-	55	-	4
15	15	M 5x10	-	55	-	4
15	15	M 5x12	-	55	-	4
15	15	M 5x15	-	55	-	4
15	15	M 6x12	-	55	-	4
15	15	M 6x16	-	55	-	4
15	15	M 6x28	-	55	-	4
15	15	M 6x50	-	55	-	4
15	15	M 4	-	55	-	5
15	15	M 5	-	55	-	5
15	15	M 6	-	55	-	5
15	18	M 5x10	-	55	-	1
15	18	M 6x12	-	55	-	1
15	18	M 4x 6	-	55	-	2
15	18	M 5x12	-	55	-	2
15	18	M 4x12	-	55	-	4
15	20	M 4x 8	-	55	-	1
15	20	M 4x10	-	55	-	1
15	20	M 4x12	-	55	-	1
15	20	M 4x13	-	55	-	1
15	20	M 5x10	M 5x15	55	-	1
15	20	M 5x12	-	55	-	1
15	20	M 5x13	-	55	-	1
15	20	M 5x15	-	55	-	1
15	20	M 5x20	-	55	-	1
15	20	M 6x18	-	55	-	1
15	20	M 6x23	-	55	-	1
15	20	M 4x 5	-	55	-	2
15	20	M 4x 6	-	55	-	2
15	20	M 4x 6	M 4x 5	55	-	2
15	20	M 4x 8	-	55	-	2
15	20	M 4x10	-	55	-	2
15	20	M 4x12	-	55	-	2
15	20	M 4x13	-	55	-	2
15	20	M 5x 4	-	55	-	2
15	20	M 5x 6	-	55	-	2

D ₁	H ₁	Thread 1 Závit 1 Винт 1 (Gxh)	Thread 2 Závit 2 Винт 2 (Gxh)	ShA ftop A	Shape Tvar Модель	Type Typ Тип
15	20	M 5x 7	-	55	-	2
15	20	M 5x 8	-	55	-	2
15	20	M 5x10	-	55	-	2
15	20	M 5x12	-	55	-	2
15	20	M 5x15	-	55	-	2
15	20	M 6x18	-	55	-	2
15	20	M 4	-	55	-	3
15	20	M 5	-	55	-	3
15	20	M 6	-	55	-	3
15	20	M 4x 6	-	55	-	4
15	20	M 4x10	-	55	-	4
15	20	M 4x13	-	55	-	4
15	20	M 5x 7	-	55	-	4
15	20	M 5x10	-	55	-	4
15	20	M 5x12	-	55	-	4
15	20	M 6x15	-	55	-	4
15	20	M 4	-	55	-	5
15	25	M 4x10	-	55	-	1
15	25	M 4x15	-	55	-	1
15	25	M 4x 6	-	55	-	2
15	25	M 4x 8	-	55	-	2
15	25	M 4x10	-	55	-	2
15	25	M 4x13	-	55	-	2
15	25	M 4x15	-	55	-	2
15	25	M 5x15	-	55	-	2
15	25	M 4	-	55	-	3
15	25	M 6	-	55	-	3
15	25	M 4x 8	-	55	-	4
15	25	M 4x10	-	55	-	4
15	25	M 4	-	55	-	5
15	26	M 4	-	55	-	3
15	30	M 3x13	-	55	-	1
15	30	M 4x10	-	55	-	1
15	30	M 4x13	-	55	-	1
15	30	M 4x15	-	55	-	1
15	30	M 5x15	-	55	-	1
15	30	M 6x15	-	55	-	1
15	30	M 6x18	-	55	-	1
15	30	M 4x 5	-	55	-	2
15	30	M 4x 8	-	55	-	2
15	30	M 4x10	-	55	-	2
15	30	M 4x12	-	55	-	2
15	30	M 4x15	-	55	-	2

Note: Thread 2 = Thread 1 unless otherwise specified. / Poznámka: Závit 2 = Závit 1 pokud není uvedeno jinak. / Заметка: Винт 2 = Винт 1, если не установлено иначе.

Type 1



Type 2



Type 3



Type 4



Type 5



D ₁	H ₁	Thread 1 Závit 1 Винт 1 (Gxh)	Thread 2 Závit 2 Винт 2 (Gxh)	ShA ftop A	Shape Tvar Модель	Type Typ Тип
15	30	M 4x20	-	55	-	2
15	30	M 5x13	-	55	-	2
15	30	M 6x10	-	55	-	2
15	30	M 4	-	55	-	3
15	30	M 5	-	55	-	3
15	30	M 6	-	55	-	3
15	30	M 4x 8	-	55	-	4
15	30	M 4x10	-	55	-	4
15	30	M 4	-	55	-	5
16	15	M 5x10	-	55	-	1
16	18	M 6x10	-	55	-	1
16	18	M 5	-	55	-	3
16	18	M 6x10	-	55	-	4
18	5,7	M 6x15	-	55	-	4
18	6	M 6x 8	-	55	-	1
18	7,5	M 6x10	-	55	-	1
18	7,5	M 5x 6	-	55	-	4
18	7,5	M 6x 8	-	55	-	4
18	7,5	M 6x10	-	55	-	4
18	7,5	M 6x15	-	55	-	4
18	7,5	M 6x16	-	55	-	4
18	7,5	M 6x18	-	55	-	4
18	7,5	M 6x25	-	55	-	4
18	8,1	M 6x16	-	55	-	1
18	8,5	M 6x13	-	55	-	1
18	8,5	M 6x15	-	55	-	1
18	8,5	M 6x16	-	55	-	1
18	13	M 6x18	-	55	-	4
18	13	M 6x20	-	55	-	4
18	14	M 6x20	-	55	-	4
18	15	M 6x10	-	55	-	1
18	15	M 6x18	-	55	-	1
18	15	M 6x18	M 6x12	55	-	1
18	20	M 6x10	-	40	42.12	1
18	20	M 6x10	-	50	42.12	1
18	20	M 6x10	-	60	42.12	1
20	20	M 6x10	M 5x 5	55	-	2
20	5	M 6x 6	-	55	-	4
20	5	M 6x 8	-	55	-	4
20	5	M 6x10	-	55	-	4
20	5	M 6x12	-	55	-	4
20	5	M 6x15	-	55	-	4
20	5	M 6x18	-	55	-	4

D ₁	H ₁	Thread 1 Závit 1 Винт 1 (Gxh)	Thread 2 Závit 2 Винт 2 (Gxh)	ShA ft op A	Shape Tvar Модель	Type Typ Тип
20	5	M 8x20	-	55	-	4
20	6	M 6x15	-	55	-	4
20	6	M 8x20	-	55	-	4
20	7	M 6x28	-	55	-	4
20	8	M 5x 8	-	55	-	1
20	8	M 5x 9	-	55	-	1
20	8	M 6x 8	-	55	-	1
20	8	M 6x10	-	55	-	1
20	8	M 6x10	M 6x 5	55	-	1
20	8	M 6x11	-	55	-	1
20	8	M 6x12	-	55	-	1
20	8	M 6x15	-	55	-	1
20	8	M 6x15	M 6x10	55	-	1
20	8	M 6x15	M 6x12	55	-	1
20	8	M 6x16	-	55	-	1
20	8	M 6x18	-	55	-	1
20	8	M 6x18	M 6x12	55	-	1
20	8	M 8x12	-	55	-	1
20	8	M 8x20	-	55	-	1
20	8	M 8x23	-	55	-	1
20	8	M 5x 8	-	55	-	4
20	8	M 5x15	-	55	-	4
20	8	M 6x 8	-	55	-	4
20	8	M 6x12	-	55	-	4
20	8	M 6x14	-	55	-	4
20	8	M 6x15	-	55	-	4
20	8	M 6x18	-	55	-	4
20	8	M 6x23	-	55	-	4
20	8	M 6x28	-	55	-	4
20	8	M 6x33	-	55	-	4
20	8	M 8x28	-	55	-	4
20	8	M 8x33	-	55	-	4
20	8	M 8x35	-	55	-	4
20	8	M10x48	-	55	-	4
20	9	M 6x15	-	55	-	1
20	10	M 4x10	-	55	-	1
20	10	M 5x 8	-	55	-	1
20	10	M 5x10	-	55	-	1
20	10	M 5x11	-	55	-	1
20	10	M 6x 6	-	55	-	1
20	10	M 6x 8	-	55	-	1
20	10	M 6x10	-	55	-	1
20	10	M 6x12	-	55	-	1

Type 1

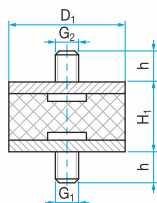

Type 2

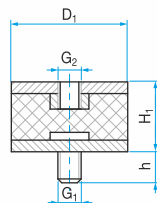

Type 3

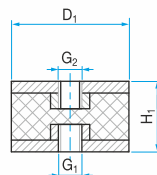

Type 4

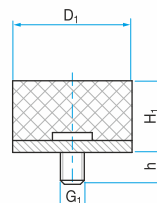

Type 5

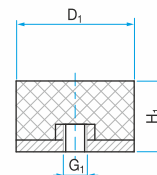

D ₁	H ₁	Thread 1 Závit 1 Винт 1 (Gxh)	Thread 2 Závit 2 Винт 2 (Gxh)	ShA ftop A	Shape Tvar Модель	Type Typ Тип
20	10	M 6x12	M 6x 5	55	-	1
20	10	M 6x15	-	55	-	1
20	10	M 6x18	-	55	-	1
20	10	M 8x20	-	55	-	1
20	10	M 4x 8	-	55	-	2
20	10	M 5x11	-	55	-	2
20	10	M 6x 5	-	55	-	2
20	10	M 6x 8	-	55	-	2
20	10	M 6x10	-	55	-	2
20	10	M 6x15	-	55	-	2
20	10	M 6x18	-	55	-	2
20	10	M 5x10	-	55	-	4
20	10	M 6x 8	-	55	-	4
20	10	M 6x10	-	55	-	4
20	10	M 6x12	-	55	-	4
20	10	M 6x15	-	55	-	4
20	10	M 6x18	-	55	-	4
20	10	M 6x24	-	55	-	4
20	10	M 6x28	-	55	-	4
20	10	M 6x38	-	55	-	4
20	10	M 8x20	-	55	-	4
20	10	M 8x23	-	55	-	4
20	10	M 4	-	55	-	5
20	10	M 6	-	55	-	5
20	11	M 5x11	-	55	-	1
20	11	M 5x11	-	55	-	2
20	11	M 6x10	-	55	-	2
20	11	M 6x18	-	55	-	4
20	11	M 6	-	55	-	5
20	12	M 5x10	-	55	-	1
20	12	M 6x 8	-	55	-	1
20	12	M 6x15	-	55	-	1
20	12	M 6x18	-	55	-	1
20	12	M 5x 6	-	55	-	2
20	12	M 6x15	-	55	-	2
20	12	M 5x 8	-	55	-	4
20	12	M 5x10	-	55	-	4
20	12	M 5x24	-	55	-	4
20	12	M 6x 6	-	55	-	4
20	12	M 6x 8	-	55	-	4
20	12	M 6x10	-	55	-	4
20	12	M 6x12	-	55	-	4
20	12	M 6x14	-	55	-	4

D ₁	H ₁	Thread 1 Závit 1 Винт 1 (Gxh)	Thread 2 Závit 2 Винт 2 (Gxh)	ShA ftop A	Shape Tvar Модель	Type Typ Тип
20	12	M 6x15	-	55	-	4
20	12	M 6x16	-	55	-	4
20	12	M 6x18	-	55	-	4
20	12	M 6x20	-	55	-	4
20	12	M 6x28	-	55	-	4
20	12	M 6x35	-	55	-	4
20	12	M 8x12	-	55	-	4
20	12	M 8x20	-	55	-	4
20	12	M 8x23	-	55	-	4
20	12	M 6	-	55	-	5
20	13	M 6x18	-	55	-	1
20	13	M 4x10	-	55	-	4
20	13	M 4x15	-	55	-	4
20	13	M 6x10	-	55	-	4
20	13	M 6x12	-	55	-	4
20	13	M 6x15	-	55	-	4
20	13	M 6x16	-	55	-	4
20	13	M 6x18	-	55	-	4
20	13	M 6x23	-	55	-	4
20	13	M 6x30	-	55	-	4
20	13	M 6	-	55	-	5
20	13,5	M 4x15	-	55	-	4
20	13,5	M 6x 8	-	55	-	4
20	13,5	M 6x15	-	55	-	4
20	13,5	M 6x18	-	55	-	4
20	13,5	M 6x24	-	55	-	4
20	13,5	M10x40	-	55	-	4
20	13,5	M 6	-	55	-	5
20	15	M 4x 8	-	55	-	1
20	15	M 4x10	-	55	-	1
20	15	M 5x13	-	55	-	1
20	15	M 5x15	-	55	-	1
20	15	M 6x 8	-	55	-	1
20	15	M 6x10	-	55	-	1
20	15	M 6x10	M 5x30	55	-	1
20	15	M 6x12	-	55	-	1
20	15	M 6x15	-	55	-	1
20	15	M 6x15	M 5x10	55	-	1
20	15	M 6x15	M 6x10	55	-	1
20	15	M 6x16	-	55	-	1
20	15	M 6x18	-	55	-	1
20	15	M 6x18	M 6x 8	55	-	1
20	15	M 6x20	M 6x10	55	-	1

Note: Thread 2 = Thread 1 unless otherwise specified. / Poznámka: Závit 2 = Závit 1 pokud není uvedeno jinak. / Заметка: Винт 2 = Винт 1, если не установлено иначе.

Type 1



Type 2



Type 3



Type 4



Type 5



D ₁	H ₁	Thread 1 Závit 1 Винт 1 (Gxh)	Thread 2 Závit 2 Винт 2 (Gxh)	ShA ftop A	Shape Tvar Модель	Type Typ Тип
20	15	M 6x28	-	55	-	1
20	15	M 8x15	-	55	-	1
20	15	M 8x15	M 8x10	55	-	1
20	15	M 8x20	-	55	-	1
20	15	M 8x23	-	55	-	1
20	15	M 4x10	-	55	-	2
20	15	M 4x12	-	55	-	2
20	15	M 4x15	-	55	-	2
20	15	M 5x 4	-	55	-	2
20	15	M 5x 8	-	55	-	2
20	15	M 5x10	-	55	-	2
20	15	M 5x12	-	55	-	2
20	15	M 5x15	-	55	-	2
20	15	M 5x19	-	55	-	2
20	15	M 6x 4	-	55	-	2
20	15	M 6x 6	-	55	-	2
20	15	M 6x 8	-	55	-	2
20	15	M 6x10	-	55	-	2
20	15	M 6x12	-	55	-	2
20	15	M 6x14	-	55	-	2
20	15	M 6x15	-	55	-	2
20	15	M 6x16	-	55	-	2
20	15	M 6x18	-	55	-	2
20	15	M 6x20	-	55	-	2
20	15	M 8x 8	-	55	-	2
20	15	M 8x15	-	55	-	2
20	15	M 5	-	55	-	3
20	15	M 6	-	55	-	3
20	15	M 8	-	55	-	3
20	15	M 5x15	-	55	-	4
20	15	M 5x18	-	55	-	4
20	15	M 6x 6	-	55	-	4
20	15	M 6x 8	-	55	-	4
20	15	M 6x10	-	55	-	4
20	15	M 6x12	-	55	-	4
20	15	M 6x15	-	55	-	4
20	15	M 6x16	-	55	-	4
20	15	M 6x18	-	55	-	4
20	15	M 6x20	-	55	-	4
20	15	M 6x23	-	55	-	4
20	15	M 6x25	-	55	-	4
20	15	M 6x30	-	55	-	4
20	15	M 6x33	-	55	-	4

D ₁	H ₁	Thread 1 Závit 1 Винт 1 (Gxh)	Thread 2 Závit 2 Винт 2 (Gxh)	ShA ft op A	Shape Tvar Модель	Type Typ Тип
20	15	M 8x 8	-	55	-	4
20	15	M 8x10	-	55	-	4
20	15	M 8x15	-	55	-	4
20	15	M 8x23	-	55	-	4
20	15	M 8x28	-	55	-	4
20	15	M 8x35	-	55	-	4
20	15	M10x39	-	55	-	4
20	15	M 5	-	55	-	5
20	15	M 6	-	55	-	5
20	15	M 8	-	55	-	5
20	17	M 6x18	-	55	-	2
20	17	M 6x 8	-	55	-	4
20	17	M 6x15	-	55	-	4
20	17	M 6x18	-	55	-	4
20	17	M 6x20	-	55	-	4
20	17	M10x28	-	55	-	4
20	18	M 6x15	-	55	-	4
20	18	M 8x15	-	55	-	4
20	18,5	M 6x10	-	55	-	2
20	20	M 5x13	-	55	-	1
20	20	M 5x15	-	55	-	1
20	20	M 5x20	-	55	-	1
20	20	M 5x25	-	55	-	1
20	20	M 6x10	-	55	-	1
20	20	M 6x10	M 5x10	55	-	1
20	20	M 6x10	M 6x18	55	-	1
20	20	M 6x14	-	55	-	1
20	20	M 6x15	-	55	-	1
20	20	M 6x15	M 6x 8	55	-	1
20	20	M 6x18	-	55	-	1
20	20	M 6x20	-	55	-	1
20	20	M 6x20	M 6x10	55	-	1
20	20	M 8x10	-	55	-	1
20	20	M 8x20	-	55	-	1
20	20	M 5x 8	-	55	-	2
20	20	M 5x12	-	55	-	2
20	20	M 5x15	-	55	-	2
20	20	M 5x18	-	55	-	2
20	20	M 6x 5	-	55	-	2
20	20	M 6x 8	-	55	-	2
20	20	M 6x10	-	55	-	2
20	20	M 6x12	-	55	-	2
20	20	M 6x15	-	55	-	2

Type 1

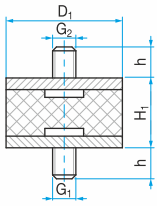

Type 2

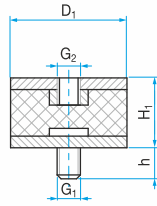

Type 3

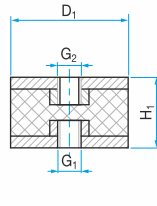

Type 4

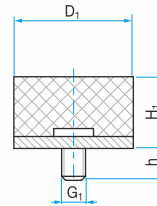

Type 5

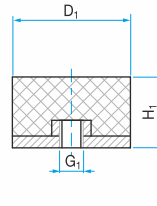

D ₁	H ₁	Thread 1 Závit 1 Винт 1 (Gxh)	Thread 2 Závit 2 Винт 2 (Gxh)	ShA ftop A	Shape Tvar Модель	Type Typ Тип
20	20	M 6x16	-	55	-	2
20	20	M 6x18	-	55	-	2
20	20	M 6x20	-	55	-	2
20	20	M 8x23	-	55	-	2
20	20	M 4	-	55	-	3
20	20	M 5	-	55	-	3
20	20	M 6	-	55	-	3
20	20	M 8	-	55	-	3
20	20	M 4x10	-	55	-	4
20	20	M 5x15	-	55	-	4
20	20	M 6x 5	-	55	-	4
20	20	M 6x 8	-	55	-	4
20	20	M 6x10	-	55	-	4
20	20	M 6x12	-	55	-	4
20	20	M 6x15	-	55	-	4
20	20	M 6x18	-	55	-	4
20	20	M 6x20	-	55	-	4
20	20	M 6x23	-	55	-	4
20	20	M 6x25	-	55	-	4
20	20	M 6x43	-	55	-	4
20	20	M 8x10	-	55	-	4
20	20	M 8x20	-	55	-	4
20	20	M 8x25	-	55	-	4
20	20	M 8x33	-	55	-	4
20	20	M 8x35	-	55	-	4
20	20	M 8x43	-	55	-	4
20	20	M 8x48	-	55	-	4
20	20	M 8x78	-	55	-	4
20	20	M10x48	-	55	-	4
20	20	M 4	-	55	-	5
20	20	M 5	-	55	-	5
20	20	M 6	-	55	-	5
20	20	M 8	-	55	-	5
20	20	M10	-	55	-	5
20	22	M 6x18	-	55	-	1
20	22	M 6x18	-	55	-	2
20	23	M 6x15	-	55	-	4
20	23	M 6x18	-	55	-	4
20	23	M 6x25	-	55	-	4
20	23	M10	-	55	-	5
20	25	M 5x13	-	55	-	1
20	25	M 5x15	-	55	-	1
20	25	M 5x18	-	55	-	1

D ₁	H ₁	Thread 1 Závit 1 Винт 1 (Gxh)	Thread 2 Závit 2 Винт 2 (Gxh)	ShA ftop A	Shape Tvar Модель	Type Typ Тип
20	25	M 6x10	-	55	-	1
20	25	M 6x10	M 6x15	55	-	1
20	25	M 6x12	-	55	-	1
20	25	M 6x14	-	55	-	1
20	25	M 6x15	-	55	-	1
20	25	M 6x18	-	55	-	1
20	25	M 6x24	-	55	-	1
20	25	M 6x25	-	55	-	1
20	25	M 6x28	-	55	-	1
20	25	M 6x28	M 6x18	55	-	1
20	25	M 6x30	-	55	-	1
20	25	M 6x35	-	55	-	1
20	25	M 6x38	-	55	-	1
20	25	M 5x11	-	55	-	2
20	25	M 5x12	-	55	-	2
20	25	M 5x15	-	55	-	2
20	25	M 6x 5	-	55	-	2
20	25	M 6x 6	-	55	-	2
20	25	M 6x 8	-	55	-	2
20	25	M 6x10	-	55	-	2
20	25	M 6x11	-	55	-	2
20	25	M 6x12	-	55	-	2
20	25	M 6x15	-	55	-	2
20	25	M 6x18	-	55	-	2
20	25	M 6x20	-	55	-	2
20	25	M 6x25	-	55	-	2
20	25	M 8x15	-	55	-	2
20	25	M 8x16	-	55	-	2
20	25	M 4	-	55	-	3
20	25	M 5	-	55	-	3
20	25	M 6	-	55	-	3
20	25	M 8	-	55	-	3
20	25	M 6x 8	-	55	-	4
20	25	M 6x10	-	55	-	4
20	25	M 6x12	-	55	-	4
20	25	M 6x15	-	55	-	4
20	25	M 6x18	-	55	-	4
20	25	M 6x25	-	55	-	4
20	25	M 8x18	-	55	-	4
20	25	M 8x20	-	55	-	4
20	25	M 6	-	55	-	5
20	30	M 6x 8	-	55	-	1
20	30	M 6x12	-	55	-	1

Note: Thread 2 = Thread 1 unless otherwise specified. / Poznámka: Závit 2 = Závit 1 pokud není uvedeno jinak. / Заметка: Винт 2 = Винт 1, если не установлено иначе.

Type 1



Type 2



Type 3



Type 4



Type 5



D ₁	H ₁	Thread 1 Závit 1 Винт 1 (Gxh)	Thread 2 Závit 2 Винт 2 (Gxh)	ShA ftop A	Shape Tvar Модель	Type Typ Тип
20	30	M 6x15	-	55	-	1
20	30	M 6x18	-	55	-	1
20	30	M 6x28	-	55	-	1
20	30	M 8x15	-	55	-	1
20	30	M 8x18	-	55	-	1
20	30	M 8x20	-	55	-	1
20	30	M 5x15	-	55	-	2
20	30	M 6x 8	-	55	-	2
20	30	M 6x12	-	55	-	2
20	30	M 6x15	-	55	-	2
20	30	M 6x18	-	55	-	2
20	30	M 8x13	-	55	-	2
20	30	M 8x15	-	55	-	2
20	30	M 8x23	-	55	-	2
20	30	M 5	-	55	-	3
20	30	M 6	-	55	-	3
20	30	M 8	-	55	-	3
20	30	M 6x12	-	55	-	4
20	30	M 6x15	-	55	-	4
20	30	M 6x18	-	55	-	4
20	30	M 8x12	-	55	-	4
20	30	M 8x20	-	55	-	4
20	30	M10x28	-	55	-	4
20	30	M 6	-	55	-	5
20	40	M 6x12	-	55	-	1
20	40	M 6	-	55	-	5
20	60	M 6x18	-	55	-	4
25	8	M 6x10	-	55	-	1
25	8	M 6x12	-	55	-	1
25	8	M 6x 6	-	55	-	4
25	8	M 6x 8	-	55	-	4
25	8	M 6x10	-	55	-	4
25	8	M 6x15	-	55	-	4
25	8	M 6x18	-	55	-	4
25	8	M 6x20	-	55	-	4
25	8	M 6x23	-	55	-	4
25	8	M 6x33	-	55	-	4
25	8	M 8x18	-	55	-	4
25	8	M 8x20	-	55	-	4
25	8	M 8x28	-	55	-	4
25	8	M 8x60	-	55	-	4
25	10	M 4x10	-	55	-	1
25	10	M 6x 8	-	55	-	1

D ₁	H ₁	Thread 1 Závit 1 Винт 1 (Gxh)	Thread 2 Závit 2 Винт 2 (Gxh)	ShA ft op A	Shape Tvar Модель	Type Typ Тип
25	10	M 6x10	-	55	-	1
25	10	M 6x11	-	55	-	1
25	10	M 6x12	-	55	-	1
25	10	M 6x15	-	55	-	1
25	10	M 6x15	M 6x11	55	-	1
25	10	M 6x16	-	55	-	1
25	10	M 6x18	-	55	-	1
25	10	M 6x18	M 6x12	55	-	1
25	10	M 6x20	-	55	-	1
25	10	M 6x28	-	55	-	1
25	10	M 8x15	-	55	-	1
25	10	M 8x18	-	55	-	1
25	10	M 8x20	-	55	-	1
25	10	M 8x28	-	55	-	1
25	10	M 6x10	-	55	-	2
25	10	M 6x18	-	55	-	2
25	10	M 5x12	-	55	-	4
25	10	M 6x10	-	55	-	4
25	10	M 6x12	-	55	-	4
25	10	M 6x15	-	55	-	4
25	10	M 6x18	-	55	-	4
25	10	M 6x20	-	55	-	4
25	10	M 6x25	-	55	-	4
25	10	M 6x28	-	55	-	4
25	10	M 8x15	-	55	-	4
25	10	M 8x20	-	55	-	4
25	10	M 8x48	-	55	-	4
25	10	M 6	-	55	-	5
25	10	M 8	-	55	-	5
25	12	M 6x18	-	55	-	1
25	12	M 6x15	-	55	-	2
25	12	M 6x 8	-	55	-	4
25	12	M 6x10	-	55	-	4
25	12	M 6x14	-	55	-	4
25	12	M 6x18	-	55	-	4
25	12	M 8x 8	-	55	-	4
25	12	M 8x15	-	55	-	4
25	12	M 8x20	-	55	-	4
25	12	M 6	-	55	-	5
25	13	M 6x10	-	55	-	1
25	13	M 6x15	-	55	-	1
25	13	M 6x18	-	55	-	1
25	13	M 6x10	-	55	-	2

Type 1

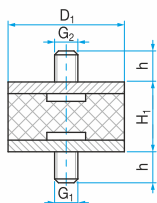

Type 2

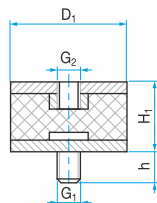

Type 3

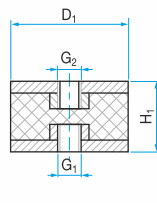

Type 4

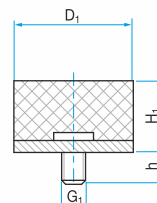

Type 5

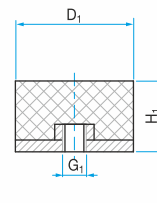

D ₁	H ₁	Thread 1 Závit 1 Винт 1 (Gxh)	Thread 2 Závit 2 Винт 2 (Gxh)	ShA ftop A	Shape Tvar Модель	Type Typ Тип
25	13	M 6x 5	-	55	-	4
25	13	M 6x10	-	55	-	4
25	13	M 6x13	-	55	-	4
25	13	M 6x15	-	55	-	4
25	13	M 6x18	-	55	-	4
25	13	M 6x25	-	55	-	4
25	13	M 8x10	-	55	-	4
25	13	M 8x25	-	55	-	4
25	13	M 6	-	55	-	5
25	14	M 6x15	-	55	-	1
25	14	M 6x16	-	55	-	4
25	14	M 6x18	-	55	-	4
25	14	M 8x18	-	55	-	4
25	14	M 8x28	-	55	-	4
25	14	M 6	-	55	-	5
25	15	M 6x 8	-	55	-	1
25	15	M 6x10	-	55	-	1
25	15	M 6x10	M 6x 6	55	-	1
25	15	M 6x12	-	55	-	1
25	15	M 6x14	-	55	-	1
25	15	M 6x15	-	55	-	1
25	15	M 6x18	-	55	-	1
25	15	M 6x18	M 6x12	55	-	1
25	15	M 6x24	-	55	-	1
25	15	M 8x15	-	55	-	1
25	15	M 8x20	-	55	-	1
25	15	M 8x25	M 8x10	55	-	1
25	15	M 6x 5	-	55	-	2
25	15	M 6x 6	-	55	-	2
25	15	M 6x 7	-	55	-	2
25	15	M 6x 8	-	55	-	2
25	15	M 6x10	-	55	-	2
25	15	M 6x12	-	55	-	2
25	15	M 6x15	-	55	-	2
25	15	M 6x18	-	55	-	2
25	15	M 6x20	-	55	-	2
25	15	M 6x23	-	55	-	2
25	15	M 8x12	-	55	-	2
25	15	M 8x15	-	55	-	2
25	15	M 8x18	-	55	-	2
25	15	M 8x23	-	55	-	2
25	15	M 6	-	55	-	3
25	15	M 5x20	-	55	-	4

D ₁	H ₁	Thread 1 Závit 1 Винт 1 (Gxh)	Thread 2 Závit 2 Винт 2 (Gxh)	ShA ftop A	Shape Tvar Модель	Type Typ Тип
25	15	M 6x 5	-	55	-	4
25	15	M 6x 6	-	55	-	4
25	15	M 6x 8	-	55	-	4
25	15	M 6x10	-	55	-	4
25	15	M 6x12	-	55	-	4
25	15	M 6x15	-	55	-	4
25	15	M 6x18	-	55	-	4
25	15	M 8x12	-	55	-	4
25	15	M 8x20	-	55	-	4
25	15	M 8x23	-	55	-	4
25	15	M 8x28	-	55	-	4
25	15	M 8x35	-	55	-	4
25	15	M 8x38	-	55	-	4
25	15	M10x28	-	55	-	4
25	15	M 5	-	55	-	5
25	15	M 6	-	55	-	5
25	15	M 8	-	55	-	5
25	17	M 6x 8	-	55	-	1
25	17	M 6x10	-	55	-	1
25	17	M 6x18	-	55	-	1
25	17	M 8x16	-	55	-	1
25	17	M 6x12	-	55	-	2
25	17	M 8x15	-	55	-	2
25	17	M 6	-	55	-	3
25	17	M 6x 8	-	55	-	4
25	17	M 6x10	-	55	-	4
25	17	M 6x12	-	55	-	4
25	17	M 6x15	-	55	-	4
25	17	M 6x18	-	55	-	4
25	17	M 6x20	-	55	-	4
25	17	M 8x18	-	55	-	4
25	17	M 8x23	-	55	-	4
25	17	M 6	-	55	-	5
25	17	M 8	-	55	-	5
25	18	M 6x12	-	55	-	1
25	18	M 8	-	55	-	3
25	18	M 6x18	-	55	-	4
25	18	M 6x25	-	55	-	4
25	18	M 8x15	-	55	-	4
25	18	M 6	-	55	-	5
25	19	M 8x20	-	55	-	1
25	19	M 8x20	-	55	-	4
25	19	M 8	-	55	-	5

Note: Thread 2 = Thread 1 unless otherwise specified. / Poznámka: Závit 2 = Závit 1 pokud není uvedeno jinak. / Заметка: Винт 2 = Винт 1, если не установлено иначе.

Type 1



Type 2



Type 3



Type 4



Type 5



D ₁	H ₁	Thread 1 Závit 1 Винт 1 (Gxh)	Thread 2 Závit 2 Винт 2 (Gxh)	ShA ftop A	Shape Tvar Модель	Type Typ Тип
25	20	M 5x10	-	55	-	1
25	20	M 5x18	-	55	-	1
25	20	M 6x10	-	55	-	1
25	20	M 6x12	-	55	-	1
25	20	M 6x12	M 6x10	55	-	1
25	20	M 6x15	-	55	-	1
25	20	M 6x18	-	55	-	1
25	20	M 6x18	M 6x10	55	-	1
25	20	M 6x20	-	55	-	1
25	20	M 6x20	M 6x10	55	-	1
25	20	M 6x28	-	55	-	1
25	20	M 6x28	M 6x12	55	-	1
25	20	M 6x12	-	40	45.12	1
25	20	M 6x12	-	50	45.12	1
25	20	M 6x12	-	60	45.12	1
25	20	M 8x10	-	55	-	1
25	20	M 8x12	-	55	-	1
25	20	M 8x13	-	55	-	1
25	20	M 8x15	-	55	-	1
25	20	M 8x18	-	55	-	1
25	20	M 8x20	-	55	-	1
25	20	M 8x23	-	55	-	1
25	20	M 8x31	-	55	-	1
25	20	M 8x31	M 8x13	55	-	1
25	20	M 8x33	-	55	-	1
25	20	M 8x33	M 8x13	55	-	1
25	20	M 5x 8	-	55	-	2
25	20	M 5x15	-	55	-	2
25	20	M 6x 6	-	55	-	2
25	20	M 6x 8	-	55	-	2
25	20	M 6x10	-	55	-	2
25	20	M 6x11	-	55	-	2
25	20	M 6x12	-	55	-	2
25	20	M 6x15	-	55	-	2
25	20	M 6x18	-	55	-	2
25	20	M 6x20	-	55	-	2
25	20	M 8x13	-	55	-	2
25	20	M 8x18	-	55	-	2
25	20	M 8x20	-	55	-	2
25	20	M10x38	-	55	-	2
25	20	M 6	-	55	-	3
25	20	M 8	-	55	-	3
25	20	M 6x 5	-	55	-	4

D ₁	H ₁	Thread 1 Závit 1 Винт 1 (Gxh)	Thread 2 Závit 2 Винт 2 (Gxh)	ShA ft op A	Shape Tvar Модель	Type Typ Тип
25	20	M 6x 6	-	55	-	4
25	20	M 6x 8	-	55	-	4
25	20	M 6x10	-	55	-	4
25	20	M 6x12	-	55	-	4
25	20	M 6x15	-	55	-	4
25	20	M 6x18	-	55	-	4
25	20	M 6x20	-	55	-	4
25	20	M 6x23	-	55	-	4
25	20	M 6x24	-	55	-	4
25	20	M 8x10	-	55	-	4
25	20	M 8x12	-	55	-	4
25	20	M 8x13	-	55	-	4
25	20	M 8x20	-	55	-	4
25	20	M 8x23	-	55	-	4
25	20	M10x25	-	55	-	4
25	20	M10x38	-	55	-	4
25	20	M 5	-	55	-	5
25	20	M 6	-	55	-	5
25	20	M 8	-	55	-	5
25	22	M 5x 6	-	55	-	1
25	22	M 6x12	-	55	-	1
25	22	M 8x20	-	55	-	1
25	22	M 8x23	-	55	-	1
25	25	M 6x 8	-	55	-	1
25	25	M 6x10	-	55	-	1
25	25	M 6x12	-	55	-	1
25	25	M 6x15	-	55	-	1
25	25	M 6x18	-	55	-	1
25	25	M 8x15	-	55	-	1
25	25	M 8x18	-	55	-	1
25	25	M 8x20	-	55	-	1
25	25	M 8x23	-	55	-	1
25	25	M 6x 8	-	55	-	2
25	25	M 6x10	-	55	-	2
25	25	M 6x12	-	55	-	2
25	25	M 6x15	-	55	-	2
25	25	M 6x18	-	55	-	2
25	25	M 8x15	-	55	-	2
25	25	M 8x16	-	55	-	2
25	25	M 8x18	-	55	-	2
25	25	M 8x20	-	55	-	2
25	25	M 8x23	-	55	-	2
25	25	M 8x35	-	55	-	2

Type 1

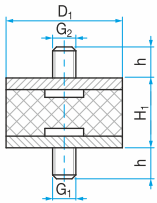

Type 2

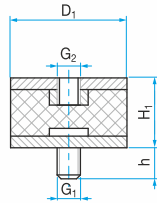

Type 3

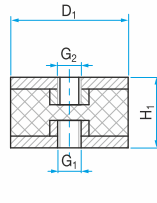

Type 4

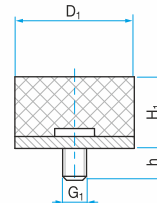

Type 5

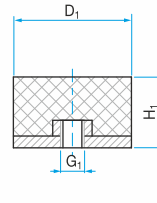

D ₁	H ₁	Thread 1 Závit 1 Винт 1 (Gxh)	Thread 2 Závit 2 Винт 2 (Gxh)	ShA ftop A	Shape Tvar Модель	Type Typ Тип
25	25	M 6	-	55	-	3
25	25	M 8	-	55	-	3
25	25	M 6x12	-	55	-	4
25	25	M 6x15	-	55	-	4
25	25	M 6x18	-	55	-	4
25	25	M 8x12	-	55	-	4
25	25	M 8x20	-	55	-	4
25	25	M 6	-	55	-	5
25	25	M 8	-	55	-	5
25	25	M10	-	55	-	5
25	27	M 8x22	-	55	-	1
25	27	M 8x22	-	55	-	2
25	27	M 6	-	55	-	3
25	27	M 8	-	55	-	3
25	27	M 6x18	-	55	-	4
25	27	M 8	-	55	-	5
25	28	M 6x15	M 6x 6	55	-	1
25	28	M 6x15	-	55	-	2
25	28	M 6x18	-	55	-	4
25	30	M 6x 8	-	55	-	1
25	30	M 6x10	-	55	-	1
25	30	M 6x12	-	55	-	1
25	30	M 6x15	-	55	-	1
25	30	M 6x18	-	55	-	1
25	30	M 6x18	M 6x12	55	-	1
25	30	M 8x15	-	55	-	1
25	30	M 8x18	-	55	-	1
25	30	M 8x20	-	55	-	1
25	30	M 8x23	-	55	-	1
25	30	M 8x25	-	55	-	1
25	30	M 5x15	-	55	-	2
25	30	M 6x 7	-	55	-	2
25	30	M 6x 8	-	55	-	2
25	30	M 6x10	-	55	-	2
25	30	M 6x12	-	55	-	2
25	30	M 6x15	-	55	-	2
25	30	M 6x18	-	55	-	2
25	30	M 6x23	-	55	-	2
25	30	M 6x28	-	55	-	2
25	30	M 8x15	-	55	-	2
25	30	M 8x20	-	55	-	2
25	30	M 8x23	-	55	-	2
25	30	M 8x35	-	55	-	2

D ₁	H ₁	Thread 1 Závit 1 Винт 1 (Gxh)	Thread 2 Závit 2 Винт 2 (Gxh)	ShA ftop A	Shape Tvar Модель	Type Typ Тип
25	30	M 6	-	55	-	3
25	30	M 8	-	55	-	3
25	30	M 6x 8	-	55	-	4
25	30	M 6x10	-	55	-	4
25	30	M 6x12	-	55	-	4
25	30	M 6x15	-	55	-	4
25	30	M 6x18	-	55	-	4
25	30	M 8x 8	-	55	-	4
25	30	M 8x15	-	55	-	4
25	30	M 8x20	-	55	-	4
25	30	M 6	-	55	-	5
25	30	M 8	-	55	-	5
25	40	M 6x12	-	55	-	1
25	40	M 6x 8	-	55	-	2
25	40	M 8	-	55	-	3
25	40	M 6x15	-	55	-	4
25	40	M 6x20	-	55	-	4
26	22	M 8x20	-	55	-	1
30	6	M 6x20	-	55	-	4
30	7	M 8x10	-	55	-	4
30	7	M10x15	-	55	-	4
30	8	M 6x18	-	55	-	4
30	8	M 8x20	-	55	-	4
30	8	M 8x28	-	55	-	4
30	10	M 5x10	-	55	-	1
30	10	M 6x12	-	55	-	1
30	10	M 8x20	-	55	-	1
30	10	M 8x28	-	55	-	1
0	10	M10x20	-	55	-	1
30	10	M10x20	M10x10	55	-	1
30	10	M 6x18	-	55	-	2
30	10	M 6x12	-	55	-	4
30	10	M 6x18	-	55	-	4
30	10	M 6x20	-	55	-	4
30	10	M 6x58	-	55	-	4
30	10	M 8x 5	-	55	-	4
30	10	M 8x10	-	55	-	4
30	10	M 8x12	-	55	-	4
30	10	M 8x13	-	55	-	4
30	10	M 8x15	-	55	-	4
30	10	M 8x20	-	55	-	4
30	10	M 8x25	-	55	-	4
30	10	M 8x33	-	55	-	4

Note: Thread 2 = Thread 1 unless otherwise specified. / Poznámka: Závit 2 = Závit 1 pokud není uvedeno jinak. / Заметка: Винт 2 = Винт 1, если не установлено иначе.

Type 1



Type 2



Type 3



Type 4



Type 5



D ₁	H ₁	Thread 1 Závit 1 Винт 1 (Gxh)	Thread 2 Závit 2 Винт 2 (Gxh)	ShA ft op A	Shape Tvar Модель	Type Typ Тип
30	10	M10x43	-	55	-	4
30	10	M10x45	-	55	-	4
30	10	M10x58	-	55	-	4
30	10	M12x58	-	55	-	4
30	10	M12x83	-	55	-	4
30	10	M 8	-	55	-	5
30	12	M 8x13	-	55	-	1
30	12	M 8x10	-	55	-	4
30	12	M 8x13	-	55	-	4
30	12	M 8x20	-	55	-	4
30	12	M 8x33	-	55	-	4
30	12	M 8	-	55	-	5
30	13	M10x52	-	55	-	4
30	15	M 6x18	-	55	-	1
30	15	M 8x 9	-	55	-	1
30	15	M 8x10	-	55	-	1
30	15	M 8x13	-	55	-	1
30	15	M 8x13	M 8x 9	55	-	1
30	15	M 8x13	M 8x10	55	-	1
30	15	M 8x15	-	55	-	1
30	15	M 8x15	M 8x10	55	-	1
30	15	M 8x17	-	55	-	1
30	15	M 8x18	-	55	-	1
30	15	M 8x19	-	55	-	1
30	15	M 8x20	-	55	-	1
30	15	M 8x21	-	55	-	1
30	15	M 8x23	-	55	-	1
30	15	M 8x23	M 8x15	55	-	1
30	15	M 8x25	-	55	-	1
30	15	M 8x28	-	55	-	1
30	15	M 8x33	-	55	-	1
30	15	M 8x50	-	55	-	1
30	15	M 8x50	M 8x15	55	-	1
30	15	M10x15	-	55	-	1
30	15	M10x18	-	55	-	1
30	15	M10x20	-	55	-	1
30	15	M10x23	-	55	-	1
30	15	M10x33	-	55	-	1
30	15	M 5x13	-	55	-	2
30	15	M 6x15	-	55	-	2
30	15	M 8x 6	-	55	-	2
30	15	M 8x10	-	55	-	2
30	15	M 8x12	-	55	-	2

D ₁	H ₁	Thread 1 Závit 1 Винт 1 (Gxh)	Thread 2 Závit 2 Винт 2 (Gxh)	ShA ft op A	Shape Tvar Модель	Type Typ Тип
30	15	M 8x13	-	55	-	2
30	15	M 8x15	-	55	-	2
30	15	M 8x18	-	55	-	2
30	15	M 8x20	-	55	-	2
30	15	M 8x23	-	55	-	2
30	15	M 8	-	55	-	3
30	15	M 8x 7	-	55	-	4
30	15	M 8x 8	-	55	-	4
30	15	M 8x10	-	55	-	4
30	15	M 8x12	-	55	-	4
30	15	M 8x13	-	55	-	4
30	15	M 8x15	-	55	-	4
30	15	M 8x20	-	55	-	4
30	15	M 8x23	-	55	-	4
30	15	M 8x25	-	55	-	4
30	15	M 8x28	-	55	-	4
30	15	M 8x33	-	55	-	4
30	15	M 8x35	-	55	-	4
30	15	M 8x38	-	55	-	4
30	15	M 8x58	-	55	-	4
30	15	M 8x68	-	55	-	4
30	15	M10x20	-	55	-	4
30	15	M10x28	-	55	-	4
30	15	M10x68	-	55	-	4
30	15	M 6	-	55	-	5
30	15	M 8	-	55	-	5
30	16	M 8x23	-	55	-	4
30	16	M 8x28	-	55	-	4
30	17	M 8x13	-	55	-	1
30	17	M 8x25	-	55	-	1
30	17	M 6x18	-	55	-	4
30	17	M 8x10	-	55	-	4
30	17	M 8x13	-	55	-	4
30	17	M 8x15	-	55	-	4
30	17	M 8x20	-	55	-	4
30	17	M 8x23	-	55	-	4
30	17	M 8x27	-	55	-	4
30	17	M 8x28	-	55	-	4
30	17	M10x15	-	55	-	4
30	17	M 8	-	55	-	5
30	17	M10	-	55	-	5
30	18	M 8x23	-	55	-	1
30	18	M10x20	-	55	-	2

Type 1

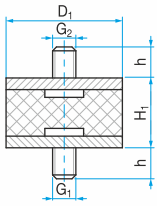

Type 2

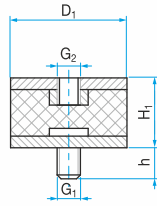

Type 3

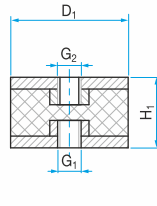

Type 4

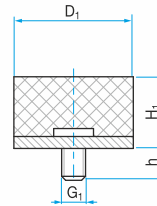

Type 5

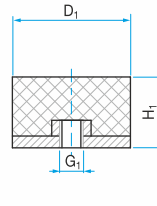

D ₁	H ₁	Thread 1 Závit 1 Винт 1 (Gxh)	Thread 2 Závit 2 Винт 2 (Gxh)	ShA ftop A	Shape Tvar Модель	Type Typ Тип
30	18	M 8x20	-	55	-	4
30	18	M 8x23	-	55	-	4
30	18	M 8x28	-	55	-	4
30	18	M 8x35	-	55	-	4
30	18	M10x10	-	55	-	4
30	18	M 8	-	55	-	5
30	18	M10	-	55	-	5
30	20	M 6x18	-	55	-	1
30	20	M 6x20	-	55	-	1
30	20	M 8x 8	-	55	-	1
30	20	M 8x10	-	55	-	1
30	20	M 8x12	-	55	-	1
30	20	M 8x12	M 6x18	55	-	1
30	20	M 8x13	-	55	-	1
30	20	M 8x15	-	55	-	1
30	20	M 8x15	M 8x 8	55	-	1
30	20	M 8x16	-	55	-	1
30	20	M 8x18	-	55	-	1
30	20	M 8x20	-	55	-	1
30	20	M 8x20	M 8x30	55	-	1
30	20	M 8x23	-	55	-	1
30	20	M 8x25	-	55	-	1
30	20	M 8x28	-	55	-	1
30	20	M 8x33	-	55	-	1
30	20	M10x10	-	55	-	1
30	20	M10x18	-	55	-	1
30	20	M10x28	-	55	-	1
30	20	M 6x10	-	55	-	2
30	20	M 6x15	-	55	-	2
30	20	M 6x18	-	55	-	2
30	20	M 6x20	-	55	-	2
30	20	M 8x 8	-	55	-	2
30	20	M 8x 9	-	55	-	2
30	20	M 8x10	-	55	-	2
30	20	M 8x12	-	55	-	2
30	20	M 8x13	-	55	-	2
30	20	M 8x15	-	55	-	2
30	20	M 8x16	-	55	-	2
30	20	M 8x18	-	55	-	2
30	20	M 8x20	-	55	-	2
30	20	M 8x23	-	55	-	2
30	20	M 8x25	-	55	-	2
30	20	M 8x28	-	55	-	2

D ₁	H ₁	Thread 1 Závit 1 Винт 1 (Gxh)	Thread 2 Závit 2 Винт 2 (Gxh)	ShA ftop A	Shape Tvar Модель	Type Typ Тип
30	20	M 8x33	-	55	-	2
30	20	M10x15	-	55	-	2
30	20	M10x28	-	55	-	2
30	20	M 6	-	55	-	3
30	20	M 8	-	55	-	3
30	20	M10	-	55	-	3
30	20	M 5x15	-	55	-	4
30	20	M 6x15	-	55	-	4
30	20	M 8x 6	-	55	-	4
30	20	M 8x10	-	55	-	4
30	20	M 8x13	-	55	-	4
30	20	M 8x15	-	55	-	4
30	20	M 8x18	-	55	-	4
30	20	M 8x20	-	55	-	4
30	20	M 8x23	-	55	-	4
30	20	M 8x27	-	55	-	4
30	20	M 8x28	-	55	-	4
30	20	M 8x33	-	55	-	4
30	20	M 8x40	-	55	-	4
30	20	M 8x48	-	55	-	4
30	20	M10x10	-	55	-	4
30	20	M10x12	-	55	-	4
30	20	M10x15	-	55	-	4
30	20	M10x20	-	55	-	4
30	20	M10x28	-	55	-	4
30	20	M12x37	-	55	-	4
30	20	M 6	-	55	-	5
30	20	M 8	-	55	-	5
30	20	M10	-	55	-	5
30	22	M 8x13	-	55	-	1
30	22	M 8x20	-	55	-	1
30	22	M 8x20	M 8x12	55	-	1
30	22	M 8x31	-	55	-	1
30	22	M 8x31	M 8x13	55	-	1
30	22	M 8x33	-	55	-	1
30	22	M 8x33	M 8x13	55	-	1
30	22	M 8x13	-	55	-	2
30	22	M 8x20	-	55	-	2
30	22	M 8x25	-	55	-	2
30	22	M 8	-	55	-	3
30	22	M 8x15	-	55	-	4
30	25	M 6x12	-	55	-	1
30	25	M 6x18	-	55	-	1

Note: Thread 2 = Thread 1 unless otherwise specified. / Poznámka: Závit 2 = Závit 1 pokud není uvedeno jinak. / Заметка: Винт 2 = Винт 1, если не установлено иначе.

Type 1



Type 2



Type 3



Type 4



Type 5



D ₁	H ₁	Thread 1 Závit 1 Винт 1 (Gxh)	Thread 2 Závit 2 Винт 2 (Gxh)	ShA ftop A	Shape Tvar Модель	Type Typ Тип
30	25	M 8x12	-	55	-	1
30	25	M 8x15	-	55	-	1
30	25	M 8x18	-	55	-	1
30	25	M 8x20	-	55	-	1
30	25	M 8x20	M 8x36	55	-	1
30	25	M 8x22	-	55	-	1
30	25	M 8x23	-	55	-	1
30	25	M 8x25	-	55	-	1
30	25	M 8x28	-	55	-	1
30	25	M 8x36	-	55	-	1
30	25	M 8x36	M 8x15	55	-	1
30	25	M10x12	-	55	-	1
30	25	M10x20	-	55	-	1
30	25	M 6x15	-	55	-	2
30	25	M 6x18	-	55	-	2
30	25	M 8x 8	-	55	-	2
30	25	M 8x10	-	55	-	2
30	25	M 8x12	-	55	-	2
30	25	M 8x15	-	55	-	2
30	25	M 8x20	-	55	-	2
30	25	M 8x23	-	55	-	2
30	25	M 8x25	-	55	-	2
30	25	M 8	-	55	-	3
30	25	M 6x 8	-	55	-	4
30	25	M 6x15	-	55	-	4
30	25	M 6x18	-	55	-	4
30	25	M 8x10	-	55	-	4
30	25	M 8x12	-	55	-	4
30	25	M 8x15	-	55	-	4
30	25	M 8x20	-	55	-	4
30	25	M 8x23	-	55	-	4
30	25	M 8x25	-	55	-	4
30	25	M 6	-	55	-	5
30	25	M 8	-	55	-	5
30	25	M10	-	55	-	5
30	27	M 8x13	-	55	-	4
30	27	M 8x20	-	55	-	4
30	28	M 8x20	-	55	-	4
30	30	M 6x18	-	55	-	1
30	30	M 6x20	-	55	-	1
30	30	M 8x13	-	55	-	1
30	30	M 8x15	-	55	-	1
30	30	M 8x15	M 8x10	55	-	1

D ₁	H ₁	Thread 1 Závit 1 Винт 1 (Gxh)	Thread 2 Závit 2 Винт 2 (Gxh)	ShA ft op A	Shape Tvar Модель	Type Typ Тип
30	30	M 8x16	-	55	-	1
30	30	M 8x17	-	55	-	1
30	30	M 8x18	-	55	-	1
30	30	M 8x20	-	55	-	1
30	30	M 8x20	M 8x36	55	-	1
30	30	M 8x23	-	55	-	1
30	30	M 8x23	M 8x15	55	-	1
30	30	M 8x25	-	55	-	1
30	30	M 8x28	-	55	-	1
30	30	M 8x31	-	55	-	1
30	30	M 8x31	M 8x13	55	-	1
30	30	M 8x33	-	55	-	1
30	30	M 8x36	-	55	-	1
30	30	M10x28	-	55	-	1
30	30	M 6x10	-	55	-	2
30	30	M 6x18	-	55	-	2
30	30	M 6x20	-	55	-	2
30	30	M 6x23	-	55	-	2
30	30	M 8x 8	-	55	-	2
30	30	M 8x 9	-	55	-	2
30	30	M 8x10	-	55	-	2
30	30	M 8x12	-	55	-	2
30	30	M 8x13	-	55	-	2
30	30	M 8x15	-	55	-	2
30	30	M 8x18	-	55	-	2
30	30	M 8x20	-	55	-	2
30	30	M 8x22	-	55	-	2
30	30	M 8x23	-	55	-	2
30	30	M 8x33	-	55	-	2
30	30	M 8x36	-	55	-	2
30	30	M 8x38	-	55	-	2
30	30	M 8	-	50	80.12	3
30	30	M 8	-	55	-	3
30	30	M10	-	55	-	3
30	30	M 6x15	-	55	-	4
30	30	M 6x18	-	55	-	4
30	30	M 6x20	-	55	-	4
30	30	M 8x 8	-	55	-	4
30	30	M 8x13	-	55	-	4
30	30	M 8x18	-	55	-	4
30	30	M 8x20	-	55	-	4
30	30	M 8x23	-	55	-	4
30	30	M 8x25	-	55	-	4

Type 1

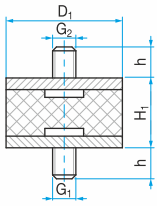

Type 2

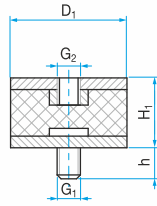

Type 3

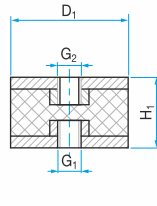

Type 4

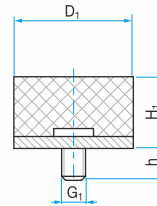

Type 5

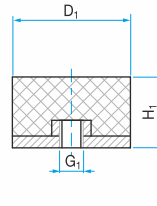

D ₁	H ₁	Thread 1 Závít 1 Винт 1 (Gxh)	Thread 2 Závít 2 Винт 2 (Gxh)	ShA ftop A	Shape Tvar Модель	Type Typ Тип
30	30	M 8x27	-	55	-	4
30	30	M 8x28	-	55	-	4
30	30	M 8x33	-	55	-	4
30	30	M 8x36	-	55	-	4
30	30	M 8x40	-	55	-	4
30	30	M10x20	-	55	-	4
30	30	M10x25	-	55	-	4
30	30	M10x28	-	55	-	4
30	30	M10x33	-	55	-	4
30	30	M 6	-	55	-	5
30	30	M 8	-	55	-	5
30	35	M 8x15	-	55	-	1
30	35	M 8x20	-	55	-	1
30	35	M 8x23	-	55	-	1
30	35	M 8x13	-	55	-	2
30	35	M 8x20	-	55	-	2
30	35	M 8x23	-	55	-	2
30	35	M 8	-	55	-	3
30	35	M 8x12	-	55	-	4
30	35	M 8x13	-	55	-	4
30	35	M 8x15	-	55	-	4
30	35	M 8x18	-	55	-	4
30	35	M 8x20	-	55	-	4
30	35	M 8x46	-	55	-	4
30	35	M 8	-	55	-	5
30	36	M 8 - 55	-	5	-	
30	40	M 6x23	-	55	-	1
30	40	M 8x20	-	55	-	1
30	40	M 8x23	-	55	-	1
30	40	M 8x23	M 8x15	55	-	1
30	40	M 8x28	-	55	-	1
30	40	M 8x28	M 8x15	55	-	1
30	40	M 8x33	-	55	-	1
30	40	M10x28	-	55	-	1
30	40	M 6x20	-	55	-	2
30	40	M 8x10	-	55	-	2
30	40	M 8x13	-	55	-	2
30	40	M 8x15	-	55	-	2
30	40	M 8x20	-	55	-	2
30	40	M 8x22	-	55	-	2
30	40	M 8x23	-	55	-	2
30	40	M 8x25	-	55	-	2
30	40	M 8x28	-	55	-	2

D ₁	H ₁	Thread 1 Závít 1 Винт 1 (Gxh)	Thread 2 Závít 2 Винт 2 (Gxh)	ShA ftop A	Shape Tvar Модель	Type Typ Тип
30	40	M10x28	-	55	-	2
30	40	M 6	-	55	-	3
30	40	M 8	-	60	30.12	3
30	40	M 8	-	55	-	3
30	40	M 8x15	-	55	-	4
30	40	M 8x20	-	55	-	4
30	40	M 8x23	-	55	-	4
30	40	M 8	-	55	-	5
30	40	M10	-	55	-	5
30	45	M 8x23	-	55	-	1
30	45	M 8x28	-	55	-	1
30	45	M 6x15	-	55	-	4
30	45	M 8x15	-	55	-	4
30	45	M 8x20	-	55	-	4
30	45	M 8x23	-	55	-	4
30	50	M 8x20	-	55	-	2
35	25	M 8x15	-	55	-	1
35	25	M 8x16	-	40	116.12	1
35	25	M 8x16	-	50	116.12	1
35	25	M 8x16	-	60	116.12	1
35	25	M 8x16	-	55	-	1
35	25	M 8x20	-	55	-	1
35	25	M 8x23	-	55	-	1
35	25	M 8x25	-	55	-	1
35	25	M10x20	-	55	-	1
35	30	M 8x36	-	55	-	1
35	30	M 8x36	M 8x20	55	-	1
35	30	M10x28	M10x10	55	-	1
35	30	M 6x18	-	55	-	2
35	30	M10x28	-	55	-	4
35	45	M 8x20	-	55	-	1
35	45	M 8x28	-	55	-	1
35	45	M 8x20	-	55	-	4
40	10	M 8x23	-	55	-	1
40	10	M 8x40	-	55	-	1
40	10	M 6x 8	-	55	-	4
40	10	M 6x10	-	55	-	4
40	10	M 8x13	-	55	-	4
40	10	M 8x15	-	55	-	4
40	10	M 8x20	-	55	-	4
40	10	M 8x23	-	55	-	4
40	10	M 8x25	-	55	-	4
40	10	M 8x28	-	55	-	4

Note: Thread 2 = Thread 1 unless otherwise specified. / Poznámka: Závít 2 = Závít 1 pokud není uvedeno jinak. / Заметка: Винт 2 = Винт 1, если не установлено иначе.

Type 1



Type 2



Type 3



Type 4



Type 5



D ₁	H ₁	Thread 1 Závit 1 Винт 1 (Gxh)	Thread 2 Závit 2 Винт 2 (Gxh)	ShA ftop A	Shape Tvar Модель	Type Typ Тип
40	10	M 8x40	-	55	-	4
40	10	M10x15	-	55	-	4
40	10	M10x28	-	55	-	4
40	10	M10	-	55	-	5
40	15	M 6x10	-	55	-	1
40	15	M 6x18	-	55	-	1
40	15	M 8x12	-	55	-	1
40	15	M 8x13	-	55	-	1
40	15	M 8x15	-	55	-	1
40	15	M 8x20	-	55	-	1
40	15	M 8x23	-	55	-	1
40	15	M 8x28	-	55	-	1
40	15	M 8x30	-	55	-	1
40	15	M10x28	-	55	-	1
40	15	M10x33	-	55	-	1
40	15	M12x30	-	55	-	1
40	15	M 8x20	-	55	-	2
40	15	M 8x23	-	55	-	2
40	15	M 8	-	55	-	3
40	15	M 6x 8	-	55	-	4
40	15	M 8x15	-	55	-	4
40	15	M 8x20	-	55	-	4
40	15	M 8x23	-	55	-	4
40	15	M 8x25	-	55	-	4
40	15	M 8x28	-	55	-	4
40	15	M10x20	-	55	-	4
40	15	M10x25	-	55	-	4
40	15	M10x28	-	55	-	4
40	15	M 6	-	55	-	5
40	15	M 8	-	55	-	5
40	15	M10	-	55	-	5
40	17	M 8x23	-	55	-	2
40	20	M 8x12	-	55	-	1
40	20	M 8x15	-	55	-	1
40	20	M 8x15	-	70	102.12	1
40	20	M 8x20	-	55	-	1
40	20	M 8x23	-	55	-	1
40	20	M 8x23	M 8x10	55	-	1
40	20	M 8x28	-	55	-	1
40	20	M 8x33	-	55	-	1
40	20	M10x15	-	55	-	1
40	20	M10x18	-	55	-	1
40	20	M10x20	-	55	-	1

D ₁	H ₁	Thread 1 Závit 1 Винт 1 (Gxh)	Thread 2 Závit 2 Винт 2 (Gxh)	ShA ft op A	Shape Tvar Модель	Type Typ Тип
40	20	M10x23	-	55	-	1
40	20	M10x25	-	55	-	1
40	20	M10x28	-	55	-	1
40	20	M10x30	-	55	-	1
40	20	M10x33	-	55	-	1
40	20	M10x36	-	55	-	1
40	20	M10x38	-	55	-	1
40	20	M10x38	M10x20	55	-	1
40	20	M 6x18	-	55	-	2
40	20	M 8x12	-	55	-	2
40	20	M 8x13	-	55	-	2
40	20	M 8x15	-	55	-	2
40	20	M 8x18	-	55	-	2
40	20	M 8x20	-	55	-	2
40	20	M 8x23	-	55	-	2
40	20	M 8x23	M 8x10	55	-	2
40	20	M 8x25	-	55	-	2
40	20	M10x13	-	55	-	2
40	20	M10x15	-	55	-	2
40	20	M10x20	-	55	-	2
40	20	M10x25	-	55	-	2
40	20	M10x28	-	55	-	2
40	20	M12x28	-	55	-	2
40	20	M 8	-	55	-	3
40	20	M 8x12	-	55	-	4
40	20	M 8x15	-	55	-	4
40	20	M 8x18	-	55	-	4
40	20	M 8x20	-	55	-	4
40	20	M 8x23	-	55	-	4
40	20	M 8x30	-	55	-	4
40	20	M 8x36	-	55	-	4
40	20	M10x10	-	55	-	4
40	20	M10x15	-	55	-	4
40	20	M10x18	-	55	-	4
40	20	M10x20	-	55	-	4
40	20	M10x23	-	55	-	4
40	20	M10x25	-	55	-	4
40	20	M10x28	-	55	-	4
40	20	M10x33	-	55	-	4
40	20	M12x33	-	55	-	4
40	20	M 8	-	55	-	5
40	20	M10	-	55	-	5
40	25	M 6x20	-	55	-	1

Type 1

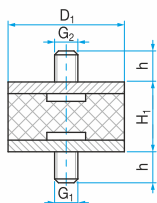

Type 2

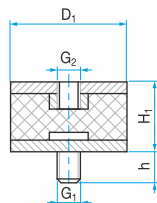

Type 3

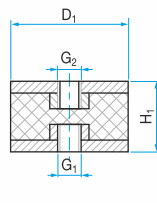

Type 4

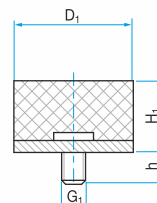

Type 5

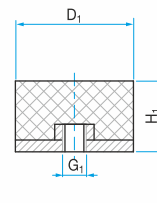

D ₁	H ₁	Thread 1 Závit 1 Винт 1 (Gxh)	Thread 2 Závit 2 Винт 2 (Gxh)	ShA ftop A	Shape Tvar Модель	Type Typ Тип
40	25	M 8x10	-	55	-	1
40	25	M 8x15	-	55	-	1
40	25	M 8x18	-	55	-	1
40	25	M 8x20	-	55	-	1
40	25	M 8x23	-	55	-	1
40	25	M 8x28	-	55	-	1
40	25	M10x25	-	55	-	1
40	25	M10x28	-	55	-	1
40	25	M10x33	-	55	-	1
40	25	M 6x23	-	55	-	2
40	25	M 8x12	-	55	-	2
40	25	M 8x15	-	55	-	2
40	25	M 8x18	-	55	-	2
40	25	M 8x20	-	55	-	2
40	25	M 8x23	-	55	-	2
40	25	M10x15	-	55	-	2
40	25	M10x20	-	55	-	2
40	25	M10x23	-	55	-	2
40	25	M10x28	-	55	-	2
40	25	M 8	-	55	-	3
40	25	M 8x15	-	55	-	4
40	25	M 8x20	-	55	-	4
40	25	M 8x23	-	55	-	4
40	25	M 8x28	-	55	-	4
40	25	M10x15	-	55	-	4
40	25	M10x25	-	55	-	4
40	25	M10x28	-	55	-	4
40	25	M10x33	-	55	-	4
40	25	M12x20	-	55	-	4
40	25	M12x30	-	55	-	4
40	25	M 8	-	55	-	5
40	25	M10	-	55	-	5
40	27	M 8x23	-	55	-	1
40	27	M 8x20	-	55	-	4
40	27	M 8	-	55	-	5
40	27	M10	-	55	-	5
40	28	M 8x23	-	55	-	1
40	28	M10x18	-	55	-	1
40	28	M10x23	-	55	-	1
40	28	M10x24	-	60	128.12	1
40	28	M10x25	-	55	-	1
40	28	M10x28	-	55	-	1
40	28	M10	-	55	-	3

D ₁	H ₁	Thread 1 Závit 1 Винт 1 (Gxh)	Thread 2 Závit 2 Винт 2 (Gxh)	ShA ftop A	Shape Tvar Модель	Type Typ Тип
40	28	M 8x 8	-	55	-	4
40	28	M 8x 9	-	55	-	4
40	28	M 8x20	-	55	-	4
40	28	M 8x23	-	55	-	4
40	28	M 8x25	-	55	-	4
40	28	M 8x28	-	55	-	4
40	28	M10x25	-	55	-	4
40	28	M10x28	-	55	-	4
40	28	M 8	-	55	-	5
40	28	M10	-	55	-	5
40	30	M 6x15	-	55	-	1
40	30	M 6x18	-	55	-	1
40	30	M 6x20	-	55	-	1
40	30	M 8x 8	-	55	-	1
40	30	M 8x 9	-	55	-	1
40	30	M 8x12	-	55	-	1
40	30	M 8x14	-	55	-	1
40	30	M 8x15	-	55	-	1
40	30	M 8x16	-	55	-	1
40	30	M 8x18	-	55	-	1
40	30	M 8x20	-	55	-	1
40	30	M 8x23	-	55	-	1
40	30	M 8x23	M 8x36	55	-	1
40	30	M 8x28	-	55	-	1
40	30	M 8x33	-	55	-	1
40	30	M 8x36	-	55	-	1
40	30	M 8x40	-	55	-	1
40	30	M10x15	-	55	-	1
40	30	M10x18	-	55	-	1
40	30	M10x20	-	55	-	1
40	30	M10x23	-	55	-	1
40	30	M10x23	M10x12	55	-	1
40	30	M10x25	-	55	-	1
40	30	M10x28	-	55	-	1
40	30	M10x33	-	55	-	1
40	30	M10x38	-	55	-	1
40	30	M 8x12	-	55	-	2
40	30	M 8x13	-	55	-	2
40	30	M 8x15	-	55	-	2
40	30	M 8x18	-	55	-	2
40	30	M 8x20	-	55	-	2
40	30	M 8x23	-	55	-	2
40	30	M 8x25	-	55	-	2

Note: Thread 2 = Thread 1 unless otherwise specified. / Poznámka: Závit 2 = Závit 1 pokud není uvedeno jinak. / Заметка: Винт 2 = Винт 1, если не установлено иначе.

Type 1



Type 2



Type 3



Type 4



Type 5



D ₁	H ₁	Thread 1 Závit 1 Винт 1 (Gxh)	Thread 2 Závit 2 Винт 2 (Gxh)	ShA ftop A	Shape Tvar Модель	Type Typ Тип
40	30	M 8x28	-	55	-	2
40	30	M 8x36	-	55	-	2
40	30	M10x13	-	55	-	2
40	30	M10x15	-	55	-	2
40	30	M10x20	-	55	-	2
40	30	M10x25	-	55	-	2
40	30	M10x28	-	55	-	2
40	30	M12x28	-	55	-	2
40	30	M 5	-	55	-	3
40	30	M 8	-	55	-	3
40	30	M10	-	55	-	3
40	30	M 6x15	-	55	-	4
40	30	M 8x10	-	55	-	4
40	30	M 8x15	-	55	-	4
40	30	M 8x20	-	55	-	4
40	30	M 8x23	-	55	-	4
40	30	M 8x25	-	55	-	4
40	30	M 8x28	-	55	-	4
40	30	M10x10	-	55	-	4
40	30	M10x20	-	55	-	4
40	30	M10x23	-	55	-	4
40	30	M10x25	-	55	-	4
40	30	M10x28	-	55	-	4
40	30	M10x33	-	55	-	4
40	30	M12x28	-	55	-	4
40	30	M 6	-	55	-	5
40	30	M 8	-	55	-	5
40	30	M10	-	55	-	5
40	30	M12	-	55	-	5
40	35	M 8x23	-	55	-	1
40	35	M 8x25	-	55	-	1
40	35	M10x20	-	55	-	1
40	35	M10x25	-	55	-	1
40	35	M10x28	-	55	-	1
40	35	M 8x15	-	55	-	2
40	35	M 8x20	-	55	-	2
40	35	M 8x23	-	55	-	2
40	35	M10x23	-	55	-	2
40	35	M10x25	-	55	-	2
40	35	M10x28	-	55	-	2
40	35	M 8	-	55	-	3
40	35	M 8x15	-	55	-	4
40	35	M 8x20	-	55	-	4

D ₁	H ₁	Thread 1 Závit 1 Винт 1 (Gxh)	Thread 2 Závit 2 Винт 2 (Gxh)	ShA ft op A	Shape Tvar Модель	Type Typ Тип
40	35	M 8x23	-	55	-	4
40	35	M 8x28	-	55	-	4
40	35	M10x25	-	55	-	4
40	35	M12x10	-	55	-	4
40	35	M 8	-	55	-	5
40	38	M 8x23	-	55	-	1
40	38	M 8x15	-	55	-	4
40	38	M 8x18	-	55	-	4
40	38	M 8x20	-	55	-	4
40	38	M 8x23	-	55	-	4
40	38	M10x12	-	55	-	4
40	40	M 8x15	-	55	-	1
40	40	M 8x16	-	55	-	1
40	40	M 8x18	-	55	-	1
40	40	M 8x20	-	55	-	1
40	40	M 8x23	-	55	-	1
40	40	M 8x25	-	55	-	1
40	40	M 8x28	-	55	-	1
40	40	M 8x33	-	55	-	1
40	40	M 8x40	-	55	-	1
40	40	M10x15	-	55	-	1
40	40	M10x20	-	55	-	1
40	40	M10x23	-	55	-	1
40	40	M10x28	-	55	-	1
40	40	M10x33	-	55	-	1
40	40	M12x28	-	55	-	1
40	40	M 8x10	-	55	-	2
40	40	M 8x12	-	55	-	2
40	40	M 8x15	-	55	-	2
40	40	M 8x20	-	55	-	2
40	40	M 8x23	-	55	-	2
40	40	M 8x28	-	55	-	2
40	40	M10x18	-	55	-	2
40	40	M10x20	-	55	-	2
40	40	M10x23	-	55	-	2
40	40	M10x28	-	55	-	2
40	40	M10x33	-	55	-	2
40	40	M12x28	-	55	-	2
40	40	M 5	-	55	-	3
40	40	M 6	-	55	-	3
40	40	M 8	-	55	-	3
40	40	M10	-	55	-	3
40	40	M 8x 8	-	55	-	4

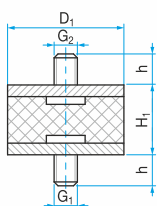
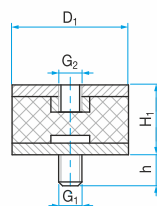
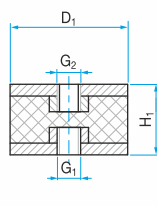
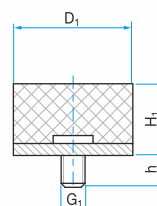
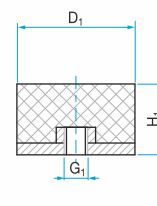
Type 1

Type 2

Type 3

Type 4

Type 5

32

D ₁	H ₁	Thread 1 Závit 1 Винт 1 (Gxh)	Thread 2 Závit 2 Винт 2 (Gxh)	ShA ftop A	Shape Tvar Модель	Type Typ Тип
40	40	M 8x12	-	55	-	4
40	40	M 8x15	-	55	-	4
40	40	M 8x20	-	55	-	4
40	40	M 8x23	-	55	-	4
40	40	M 8x25	-	55	-	4
40	40	M 8x28	-	55	-	4
40	40	M10x15	-	55	-	4
40	40	M10x20	-	55	-	4
40	40	M10x25	-	55	-	4
40	40	M10x28	-	55	-	4
40	40	M 8	-	55	-	5
40	40	M10	-	55	-	5
40	45	M 8x23	-	55	-	1
40	45	M 8x28	-	55	-	1
40	45	M10x15	-	55	-	1
40	45	M10x28	-	55	-	1
40	45	M10x12	-	55	-	2
40	45	M10x28	-	55	-	2
40	45	M 8x12	-	55	-	4
40	45	M10x25	-	55	-	4
40	45	M12x26	-	55	-	4
40	45	M 8	-	55	-	5
40	50	M10x20	-	55	-	1
40	50	M10x23	-	55	-	1
40	50	M10x28	-	55	-	1
40	50	M 8	-	55	-	3
40	50	M 8x23	-	55	-	4
40	50	M 8	-	55	-	5
40	55	M 8	-	55	-	3
40	60	M 8x15	-	55	-	1
40	60	M 8x23	-	55	-	1
40	60	M10x20	-	55	-	1
40	60	M12x20	-	55	-	1
40	60	M12x30	-	55	-	1
40	60	M 8x20	-	55	-	2
40	60	M10x20	-	55	-	2
40	60	M10x28	-	55	-	2
40	60	M 8	-	55	-	3
43	45	M 8	-	55	-	3
45	50	M 8x23	-	55	-	1
45	50	M 8x23	-	55	-	2
50	7	M 6x 8	-	55	-	4
50	9	M10x28	-	55	-	4

D ₁	H ₁	Thread 1 Závit 1 Винт 1 (Gxh)	Thread 2 Závit 2 Винт 2 (Gxh)	ShA ftop A	Shape Tvar Модель	Type Typ Тип
50	10	M10x10	-	55	-	4
50	10	M10x15	-	55	-	4
50	10	M10x18	-	55	-	4
50	10	M10x20	-	55	-	4
50	10	M10x28	-	55	-	4
50	12	M 6x12	-	55	-	4
50	12	M 6x16	-	55	-	4
50	12	M 8x12	-	55	-	4
50	12	M10x28	-	55	-	4
50	12	M10x38	-	55	-	4
50	12	M10	-	55	-	5
50	15	M10x20	-	55	-	1
50	15	M 8x 8	-	55	-	4
50	15	M 8x15	-	55	-	4
50	15	M10x10	-	55	-	4
50	15	M10x15	-	55	-	4
50	15	M10x23	-	55	-	4
50	15	M10x28	-	55	-	4
50	15	M10x38	-	55	-	4
50	15	M10x50	-	55	-	4
50	15	M12x45	-	55	-	4
50	15	M 6	-	55	-	5
50	17	M10x28	-	55	-	1
50	17	M 8x28	-	55	-	4
50	17	M10x10	-	55	-	4
50	17	M10x25	-	55	-	4
50	17	M10x28	-	55	-	4
50	17	M10x33	-	55	-	4
50	17	M12x28	-	55	-	4
50	17	M10	-	55	-	5
50	18	M10x25	-	55	-	4
50	20	M 6x15	-	55	-	1
50	20	M 8x15	-	55	-	1
50	20	M 8x20	-	55	-	1
50	20	M 8x38	-	55	-	1
50	20	M10x12	-	55	-	1
50	20	M10x15	-	55	-	1
50	20	M10x18	-	55	-	1
50	20	M10x20	-	55	-	1
50	20	M10x20	M10x10	55	-	1
50	20	M10x28	-	55	-	1
50	20	M10x28	M10x12	55	-	1
50	20	M10x28	M10x15	55	-	1

Note: Thread 2 = Thread 1 unless otherwise specified. / Poznámka: Závit 2 = Závit 1 pokud není uvedeno jinak. / Заметка: Винт 2 = Винт 1, если не установлено иначе.

Type 1



Type 2



Type 3



Type 4



Type 5



D ₁	H ₁	Thread 1 Závit 1 Винт 1 (Gxh)	Thread 2 Závit 2 Винт 2 (Gxh)	ShA ftop A	Shape Tvar Модель	Type Typ Тип
50	20	M10x28	M10x20	55	-	1
50	20	M10x28	M10x38	55	-	1
50	20	M10x33	-	55	-	1
50	20	M10x37	M10x27	55	-	1
50	20	M10x38	-	55	-	1
50	20	M10x41	-	55	-	1
50	20	M10x45	-	55	-	1
50	20	M12x25	-	55	-	1
50	20	M12x28	-	55	-	1
50	20	M12x37	-	55	-	1
50	20	M 8x15	-	55	-	2
50	20	M 8x23	-	55	-	2
50	20	M 8x28	-	55	-	2
50	20	M10x 5	-	55	-	2
50	20	M10x10	-	55	-	2
50	20	M10x12	-	55	-	2
50	20	M10x13	-	55	-	2
50	20	M10x15	-	55	-	2
50	20	M10x16	-	55	-	2
50	20	M10x20	-	55	-	2
50	20	M10x25	-	55	-	2
50	20	M10x28	-	55	-	2
50	20	M10x30	-	55	-	2
50	20	M10x33	-	55	-	2
50	20	M10x38	-	55	-	2
50	20	M10x43	-	55	-	2
50	20	M12x20	-	55	-	2
50	20	M12x28	-	55	-	2
50	20	M12x33	-	55	-	2
50	20	M12x43	-	55	-	2
50	20	M10 - 55	-	3	-	
50	20	M 6x16	-	55	-	4
50	20	M 8x28	-	55	-	4
50	20	M10x14	-	55	-	4
50	20	M10x15	-	55	-	4
50	20	M10x18	-	55	-	4
50	20	M10x20	-	55	-	4
50	20	M10x25	-	55	-	4
50	20	M10x28	-	55	-	4
50	20	M10x33	-	55	-	4
50	20	M10x38	-	55	-	4
50	20	M12x28	-	55	-	4
50	20	M12x33	-	55	-	4

D ₁	H ₁	Thread 1 Závit 1 Винт 1 (Gxh)	Thread 2 Závit 2 Винт 2 (Gxh)	ShA ft op A	Shape Tvar Модель	Type Typ Тип
50	20	M12x38	-	55	-	4
50	20	M12x40	-	55	-	4
50	20	M12x48	-	55	-	4
50	20	M 8	-	55	-	5
50	20	M10	-	55	-	5
50	21	M10x10	-	55	-	2
50	21	M10x20	-	55	-	2
50	21	M10x30	-	55	-	2
50	21	M10x20	-	55	-	4
50	21	M10x48	-	55	-	4
50	21	M10	-	55	-	5
50	25	M 8x23	-	55	-	1
50	25	M10x20	-	55	-	1
50	25	M10x25	-	55	-	1
50	25	M10x27	-	55	-	1
50	25	M10x28	-	55	-	1
50	25	M10x33	-	55	-	1
50	25	M12x25	-	55	-	1
50	25	M12x37	-	55	-	1
50	25	M10x13	-	55	-	2
50	25	M10x20	-	55	-	2
50	25	M10x28	-	55	-	2
50	25	M 8	-	55	-	3
50	25	M10	-	55	-	3
50	25	M10x15	-	55	-	4
50	25	M10x20	-	55	-	4
50	25	M10x28	-	55	-	4
50	25	M10x33	-	55	-	4
50	25	M12x28	-	55	-	4
50	25	M 8 - 55	-	5	-	
50	25	M10 - 55	-	5	-	
50	25	M12 - 55	-	5	-	
50	25	M16 - 55	-	5	-	
50	27	M12x37	-	55	-	2
50	28	M10x28	-	55	-	4
50	28	M10x33	-	55	-	4
50	28	M10x34	-	55	-	4
50	28	M10 - 55	-	5	-	
50	30	M 6x15	-	55	-	1
50	30	M 8x28	-	55	-	1
50	30	M10x10	-	55	-	1
50	30	M10x16	-	55	-	1
50	30	M10x17	-	55	-	1

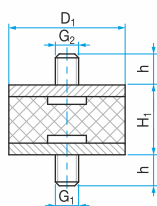
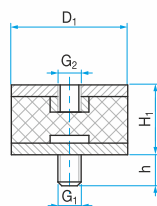
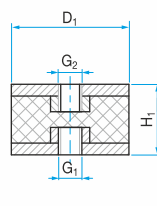
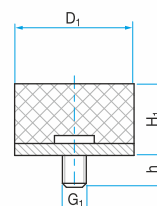
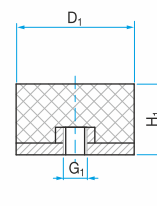
Type 1

Type 2

Type 3

Type 4

Type 5

34

D ₁	H ₁	Thread 1 Závít 1 Винт 1 (Gxh)	Thread 2 Závít 2 Винт 2 (Gxh)	ShA ftop A	Shape Tvar Модель	Type Typ Тип
50	30	M10x20	-	55	-	1
50	30	M10x25	-	55	-	1
50	30	M10x28	-	55	-	1
50	30	M10x28	M10x38	55	-	1
50	30	M10x33	-	55	-	1
50	30	M10x34	-	55	-	1
50	30	M12x28	-	55	-	1
50	30	M 8x12	-	55	-	2
50	30	M 8x28	-	55	-	2
50	30	M10x10	-	55	-	2
50	30	M10x15	-	55	-	2
50	30	M10x16	-	55	-	2
50	30	M10x17	-	55	-	2
50	30	M10x18	-	55	-	2
50	30	M10x19	-	70	222.12	2
50	30	M10x20	-	55	-	2
50	30	M10x23	-	55	-	2
50	30	M10x25	-	55	-	2
50	30	M10x28	-	55	-	2
50	30	M10x43	-	55	-	2
50	30	M12x28	-	55	-	2
50	30	M16x43	M10	55	-	2
50	30	M 5	-	55	-	3
50	30	M 8	-	55	-	3
50	30	M10	-	55	-	3
50	30	M12	-	55	-	3
50	30	M 8x23	-	55	-	4
50	30	M 8x28	-	55	-	4
50	30	M10x28	-	55	-	4
50	30	M12x23	-	55	-	4
50	30	M12x28	-	55	-	4
50	30	M10	-	55	-	5
50	30	M12	-	55	-	5
50	35	M10x20	-	55	-	1
50	35	M10x25	-	55	-	1
50	35	M10x28	-	55	-	1
50	35	M10x33	-	55	-	1
50	35	M10x12	-	55	-	2
50	35	M10x23	-	55	-	2
50	35	M10	-	55	-	3
50	35	M10x28	-	55	-	4
50	35	M12	-	55	-	5
50	37,5	M10	-	55	-	3

D ₁	H ₁	Thread 1 Závít 1 Винт 1 (Gxh)	Thread 2 Závít 2 Винт 2 (Gxh)	ShA ftop A	Shape Tvar Модель	Type Typ Тип
50	37,5	M10x28	-	55	-	4
50	37,5	M10	-	55	-	5
50	40	M 8x23	-	55	-	1
50	40	M 8x28	-	55	-	1
50	40	M10x15	-	55	-	1
50	40	M10x17	-	55	-	1
50	40	M10x20	-	40	63.12	1
50	40	M10x20	-	50	63.12	1
50	40	M10x20	-	60	63.12	1
50	40	M10x20	-	55	-	1
50	40	M10x23	-	55	-	1
50	40	M10x25	-	55	-	1
50	40	M10x28	-	55	-	1
50	40	M10x28	M10x17	55	-	1
50	40	M10x30	-	55	-	1
50	40	M10x34	-	55	-	1
50	40	M10x35	-	55	-	1
50	40	M12x20	-	55	-	1
50	40	M12x21	-	55	-	1
50	40	M12x28	-	55	-	1
50	40	M12x38	-	55	-	1
50	40	M12x43	-	55	-	1
50	40	M16x38	-	55	-	1
50	40	M10x15	-	55	-	2
50	40	M10x18	-	55	-	2
50	40	M10x19	-	40	217.12	2
50	40	M10x19	-	50	217.12	2
50	40	M10x19	-	60	217.12	2
50	40	M10x20	-	55	-	2
50	40	M10x24	-	55	-	2
50	40	M10x25	-	55	-	2
50	40	M10x28	-	55	-	2
50	40	M10x33	-	55	-	2
50	40	M 8	-	55	-	3
50	40	M10	-	55	-	3
50	40	M12	-	55	-	3
50	40	M10x10	-	55	-	4
50	40	M10x15	-	55	-	4
50	40	M10x20	-	55	-	4
50	40	M10x22	-	55	-	4
50	40	M10x23	-	55	-	4
50	40	M10x25	-	55	-	4
50	40	M10x28	-	55	-	4

Note: Thread 2 = Thread 1 unless otherwise specified. / Poznámka: Závít 2 = Závít 1 pokud není uvedeno jinak. / Заметка: Винт 2 = Винт 1, если не установлено иначе.

Type 1



Type 2



Type 3



Type 4



Type 5



D ₁	H ₁	Thread 1 Závit 1 Винт 1 (Gxh)	Thread 2 Závit 2 Винт 2 (Gxh)	ShA ftop A	Shape Tvar Модель	Type Typ Тип
50	40	M10x37	-	55	-	4
50	40	M12x38	-	55	-	4
50	40	M10	-	55	-	5
50	40	M12	-	55	-	5
50	42	M10x28	-	55	-	4
50	45	M 8x13	-	55	-	1
50	45	M 8x23	-	55	-	1
50	45	M 8x28	-	55	-	1
50	45	M10x28	-	55	-	1
50	45	M10x33	-	55	-	1
50	45	M 8x23	-	55	-	2
50	45	M 8x28	-	55	-	2
50	45	M10x10	-	55	-	2
50	45	M10x15	-	55	-	2
50	45	M10x20	-	55	-	2
50	45	M10x23	-	55	-	2
50	45	M10x25	-	55	-	2
50	45	M10x28	-	55	-	2
50	45	M10x30	-	55	-	2
50	45	M10x33	-	55	-	2
50	45	M10x33	M10x12	55	-	2
50	45	M10x34	-	55	-	2
50	45	M10x38	-	55	-	2
50	45	M10x43	-	55	-	2
50	45	M12x28	-	55	-	2
50	45	M12x37	-	55	-	2
50	45	M10	-	55	-	3
50	45	M12	-	55	-	3
50	45	M10x25	-	55	-	4
50	45	M10x28	-	55	-	4
50	45	M10x33	-	55	-	4
50	45	M 8	-	55	-	5
50	45	M10	-	55	-	5
50	50	M 8x23	-	55	-	1
50	50	M 8x28	-	55	-	1
50	50	M10x10	-	55	-	1
50	50	M10x18	-	55	-	1
50	50	M10x25	-	55	-	1
50	50	M10x28	-	55	-	1
50	50	M10x33	-	55	-	1
50	50	M12x37	-	55	-	1
50	50	M10x23	-	55	-	2
50	50	M10x25	-	55	-	2

D ₁	H ₁	Thread 1 Závit 1 Винт 1 (Gxh)	Thread 2 Závit 2 Винт 2 (Gxh)	ShA ft op A	Shape Tvar Модель	Type Typ Тип
50	50	M10x28	-	55 - 2	-	
50	50	M10x33	-	55	-	2
50	50	M10x34	-	55	-	2
50	50	M 8	-	55	-	3
50	50	M10	-	55	-	3
50	50	M10x15	-	55	-	4
50	50	M10x20	-	55	-	4
50	50	M10x25	-	55	-	4
50	50	M10x28	-	55	-	4
50	50	M10x33	-	55	-	4
50	50	M12x18	-	55	-	4
50	50	M10 - 55	-	5	-	
50	50	M12 - 55	-	5	-	
50	55	M10x28	-	55	-	1
50	55	M10x28	-	55	-	2
50	55	M12x28	-	55	-	2
50	55	M12x28	M10	55	-	2
50	55	M 8	-	55	-	3
50	55	M12	-	55	-	3
50	55	M10x28	-	55	-	4
50	60	M10x15	-	55	-	2
50	60	M10x28	-	55	-	2
50	60	M10x15	-	55	-	4
50	60	M10x20	-	55	-	4
50	60	M10x28	-	55	-	4
50	60	M10 - 55	-	5	-	
50	65	M10x25	-	55	-	1
50	70	M10 - 55	-	3	-	
50	70	M10x28	-	55	-	4
50	70	M10x38	-	55	-	4
50	80	M10x27	-	55	-	1
50	80	M10x15	-	55	-	4
50	80	M10x28	-	55	-	4
60	15	M10x25	-	55	-	4
60	15	M12x30	-	55	-	4
60	16	M10x42	-	55	-	4
60	20	M10x28	-	55	-	2
60	20	M 8x16	-	55	-	4
60	20	M10x28	-	55	-	4
60	20	M10x38	-	55	-	4
60	20	M10x42	-	55	-	4
60	20	M12x37	-	55	-	4
60	25	M 6x20	-	55	-	1

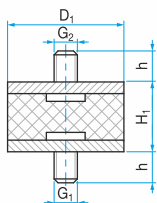
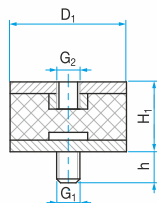
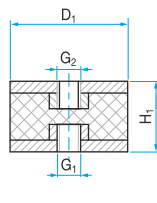
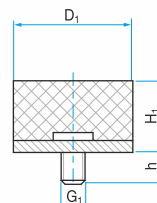
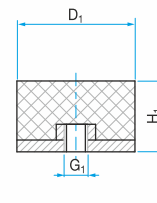
Type 1

Type 2

Type 3

Type 4

Type 5

36

D ₁	H ₁	Thread 1 Závit 1 Винт 1 (Gxh)	Thread 2 Závit 2 Винт 2 (Gxh)	ShA ftop A	Shape Tvar Модель	Type Typ Тип
60	25	M 8x20	-	55	-	1
60	25	M10x25	-	55	-	1
60	25	M10x25	M10x12	55	-	1
60	25	M10x28	-	55	-	1
60	25	M12x37	-	55	-	1
60	25	M16x47	-	55	-	1
60	25	M10x28	-	55	-	2
60	25	M10x20	-	55	-	4
60	25	M10x25	-	55	-	4
60	25	M10x28	-	55	-	4
60	25	M16x42	-	55	-	4
60	25	M10	-	55	-	5
60	25	M12	-	55	-	5
60	30	M10x28	-	55	-	1
60	30	M12x23	-	55	-	1
60	30	M12x25	-	55	-	1
60	30	M12x33	-	55	-	1
60	30	M12x37	-	55	-	1
60	30	M10x20	-	55	-	2
60	30	M10x28	-	55	-	2
60	30	M10x33	-	55	-	2
60	30	M12x28	-	55	-	2
60	30	M12x33	-	55	-	2
60	30	M12x37	-	55	-	2
60	30	M 8	-	55	-	3
60	30	M10	-	55	-	3
60	30	M12	-	55	-	3
60	30	M16	-	55	-	3
60	30	M 8x20	-	55	-	4
60	30	M10x20	-	55	-	4
60	30	M10x28	-	55	-	4
60	30	M10x38	-	55	-	4
60	30	M12x33	-	55	-	4
60	30	M12x37	-	55	-	4
60	30	M 8	-	55	-	5
60	30	M10	-	55	-	5
60	30	M12	-	55	-	5
60	35	M 8x28	-	55	-	1
60	35	M10x20	-	55	-	1
60	35	M10x25	-	55	-	1
60	35	M10x28	-	55	-	1
60	35	M12x33	-	55	-	1
60	35	M12x37	-	55	-	1

D ₁	H ₁	Thread 1 Závit 1 Винт 1 (Gxh)	Thread 2 Závit 2 Винт 2 (Gxh)	ShA ftop A	Shape Tvar Модель	Type Typ Тип
60	35	M10x15	-	55	-	2
60	35	M10x20	-	55	-	2
60	35	M10x25	-	55	-	2
60	35	M10x28	-	55	-	2
60	35	M12x18	-	55	-	2
60	35	M12x27	-	55	-	2
60	35	M10	-	55	-	3
60	35	M12	-	55	-	3
60	35	M 8x33	-	55	-	4
60	35	M10x28	-	55	-	4
60	35	M10x70	-	55	-	4
60	35	M12	-	55	-	5
60	40	M 8x33	-	55	-	1
60	40	M10x28	-	55	-	1
60	40	M10x33	M10x27	55	-	1
60	40	M12x20	-	55	-	1
60	40	M12x25	-	55	-	1
60	40	M12x28	-	55	-	1
60	40	M12x33	-	55	-	1
60	40	M12x37	-	55	-	1
60	40	M10x28	-	55	-	2
60	40	M12x20	-	55	-	2
60	40	M12x23	-	55	-	2
60	40	M12x25	-	55	-	2
60	40	M12x28	-	55	-	2
60	40	M12x33	-	55	-	2
60	40	M12x37	-	55	-	2
60	40	M10x28	-	55	-	2
60	40	M12x20	-	55	-	2
60	40	M12x23	-	55	-	2
60	40	M12x25	-	55	-	2
60	40	M12x28	-	55	-	2
60	40	M12x33	-	55	-	2
60	40	M12x37	-	55	-	2
60	40	M10	-	55	-	3
60	40	M12	-	55	-	3
60	40	M12x35	-	55	-	2
60	40	M12x37	-	55	-	2
60	40	M10	-	55	-	3
60	40	M12	-	55	-	3
60	40	M16	-	55	-	3
60	40	M10x28	-	55	-	4
60	40	M10x58	-	55	-	4
60	40	M10x70	-	55	-	4
60	40	M12x23	-	55	-	4
60	40	M12x33	-	55	-	4
60	40	M10	-	55	-	5
60	40	M12	-	55	-	5
60	40	M12x38	-	55	-	1
60	45	M 8x23	-	55	-	1
60	45	M10x28	-	55	-	1
60	45	M10x38	-	55	-	1
60	45	M12x28	-	55	-	1

Note: Thread 2 = Thread 1 unless otherwise specified. / Poznámka: Závit 2 = Závit 1 pokud není uvedeno jinak. / Заметка: Винт 2 = Винт 1, если не установлено иначе.

Type 1



Type 2



Type 3



Type 4



Type 5



D ₁	H ₁	Thread 1 Závit 1 Винт 1 (Gxh)	Thread 2 Závit 2 Винт 2 (Gxh)	ShA ftop A	Shape Tvar Модель	Type Typ Тип
60	45	M12x30	-	55	-	1
60	45	M12x33	-	55	-	1
60	45	M10x20	-	55	-	2
60	45	M12x37	-	55	-	2
60	45	M10x28	-	55	-	4
60	50	M 8x28	-	55	-	1
60	50	M10x20	-	55	-	1
60	50	M10x28	-	55	-	1
60	50	M12x28	-	55	-	1
60	50	M12x33	-	55	-	1
60	50	M12x37	-	55	-	1
60	50	M10x20	-	55	-	2
60	50	M10x28	-	55	-	2
60	50	M10x33	-	55	-	2
60	50	M12x37	-	55	-	2
60	50	M12	-	55	-	3
60	50	M10x28	-	55	-	4
60	50	M12x33	-	55	-	4
60	50	M12x37	-	55	-	4
60	50	M10	-	55	-	5
60	50	M12	-	55	-	5
60	60	M10x20	-	55	-	1
60	60	M10x25	-	55	-	1
60	60	M10x28	-	55	-	1
60	60	M10x38	-	55	-	1
60	60	M12x28	-	55	-	1
60	60	M12x38	-	55	-	1
60	60	M12	-	55	-	3
60	60	M16	-	55	-	3
60	60	M10x20	-	55	-	4
60	60	M10x23	-	55	-	4
60	60	M10x28	-	55	-	4
60	60	M10x38	-	55	-	4
60	60	M12x23	-	55	-	4
60	60	M12x28	-	55	-	4
60	60	M12x37	-	55	-	4
60	60	M10	-	55	-	5
64	35	M10x18	-	40	141.12	1
64	35	M10x18	-	60	141.12	1
65	35	M10x20	-	55	-	1
65	35	M10x28	-	55	-	1
65	35	M12x25	-	55	-	1
65	35	M12x37	-	55	-	1

D ₁	H ₁	Thread 1 Závit 1 Винт 1 (Gxh)	Thread 2 Závit 2 Винт 2 (Gxh)	ShA ft op A	Shape Tvar Модель	Type Typ Тип
65	35	M10x16,5	-	40	32.12	2
65	35	M10x16,5	-	70	32.12	2
65	35	M12x18	-	55	-	2
65	35	M12 -	55	-	3	
70	20	M10x28	-	55	-	1
70	20	M 8x23	-	55	-	4
70	20	M10x38	-	55	-	4
70	20	M12x37	-	55	-	4
70	20	M14x20	-	55	-	4
70	25	M12x37	-	55	-	1
70	25	M10x20	-	55	-	2
70	25	M12x33	-	55	-	2
70	25	M12x37	-	55	-	2
70	25	M10x25	-	55	-	4
70	25	M10x28	-	55	-	4
70	25	M10x32	-	55	-	4
70	25	M10x35	-	55	-	4
70	25	M10x85	-	55	-	4
70	25	M12x18	-	55	-	4
70	25	M10	-	55	-	5
70	25	M12	-	55	-	5
70	30	M12x37	-	55	-	1
70	30	M12x37	-	55	-	2
70	30	M10 - 55	-	3	-	
70	30	M12x33	-	55	-	4
70	30	M16x37	-	55	-	4
70	30	M10 - 55	-	5	-	
70	30	M12 - 55	-	5	-	
70	35	M10x25	-	55	-	1
70	35	M10x28	-	55	-	1
70	35	M10x38	-	55	-	1
70	35	M12x28	-	55	-	1
70	35	M12x37	-	55	-	1
70	35	M12x28	-	55	-	2
70	35	M10	-	55	-	3
70	35	M12	-	55	-	3
70	35	M10x25	-	55	-	4
70	35	M10x28	-	55	-	4
70	35	M12x40	-	55	-	4
70	35	M10	-	55	-	5
70	40	M 8x18	-	55	-	1
70	40	M10x25	-	55	-	1
70	40	M10x28	-	55	-	1

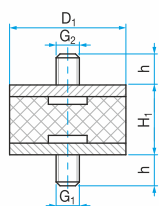
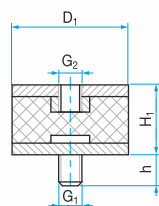
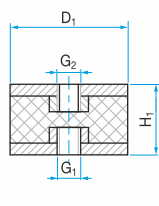
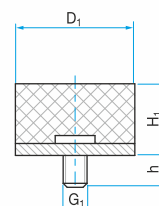
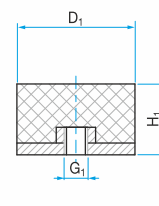
Type 1

Type 2

Type 3

Type 4

Type 5

38

D ₁	H ₁	Thread 1 Závít 1 Винт 1 (Gxh)	Thread 2 Závít 2 Винт 2 (Gxh)	ShA ftop A	Shape Tvar Модель	Type Typ Тип
70	40	M12x25	-	55	-	1
70	40	M12x28	-	55	-	1
70	40	M12x37	-	55	-	1
70	40	M10x15	-	55	-	2
70	40	M10x28	-	55	-	2
70	40	M12x37	-	55	-	2
70	40	M10	-	55	-	3
70	40	M12	-	55	-	3
70	40	M10x25	-	55	-	4
70	40	M10x28	-	55	-	4
70	40	M12x37	-	55	-	4
70	40	M12	-	55	-	5
70	45	M10x25	-	55	-	1
70	45	M10x28	-	55	-	1
70	45	M10x30	-	55	-	1
70	45	M10x33	-	55	-	1
70	45	M10x43	-	55	-	1
70	45	M12x37	-	55	-	1
70	45	M10x23	-	55	-	2
70	45	M10x25	-	55	-	2
70	45	M10x28	-	55	-	2
70	45	M10x30	-	55	-	2
70	45	M10x38	-	55	-	2
70	45	M10x43	-	55	-	2
70	45	M12x10	-	55	-	2
70	45	M12x13	-	55	-	2
70	45	M12x23	-	55	-	2
70	45	M12x24	-	55	-	2
70	45	M12x33	-	55	-	2
70	45	M12x37	-	55	-	2
70	45	M16x20	-	55	-	2
70	45	M8	-	55	-	3
70	45	M10	-	55	-	3
70	45	M12	-	55	-	3
70	45	M16	-	55	-	3
70	45	M10x25	-	55	-	4
70	45	M10x28	-	55	-	4
70	45	M10x38	-	55	-	4
70	45	M12x37	-	55	-	4
70	45	M10	-	55	-	5
70	45	M12	-	55	-	5
70	48	M12x24	-	40	87.12	1
70	48	M12x24	-	50	87.12	1

D ₁	H ₁	Thread 1 Závít 1 Винт 1 (Gxh)	Thread 2 Závít 2 Винт 2 (Gxh)	ShA ftop A	Shape Tvar Модель	Type Typ Тип
70	48	M12x24	-	60	87.12	1
70	50	M10x28	-	55	-	1
70	50	M12x27	-	55	-	1
70	50	M12x37	-	55	-	1
70	50	M10x25	-	55	-	2
70	50	M10x28	-	55	-	2
70	50	M12x37	-	55	-	2
70	50	M10	-	55	-	3
70	50	M12	-	55	-	3
70	50	M12x37	-	55	-	4
70	50	M10	-	55	-	5
70	50	M12	-	55	-	5
70	55	M12x37	-	55	-	1
70	55	M12x37	-	55	-	2
70	55	M10	-	55	-	3
70	55	M12	-	55	-	3
70	55	M10x33	-	55	-	4
70	55	M12x37	-	55	-	4
70	55	M12	-	55	-	5
70	60	M10x25	-	55	-	1
70	60	M10x28	-	55	-	1
70	60	M10x37	-	55	-	1
70	60	M12x37	-	55	-	1
70	60	M10x25	-	55	-	2
70	60	M10x28	-	55	-	2
70	60	M12x37	-	55	-	2
70	60	M12	-	55	-	3
70	60	M10x28	-	55	-	4
70	60	M12x37	-	55	-	4
70	70	M10x28	-	55	-	1
70	70	M12x27	-	55	-	1
70	70	M12x37	-	55	-	1
70	70	M10x28	-	55	-	2
70	70	M12x37	-	55	-	2
70	70	M16x27	-	55	-	2
70	70	M10	-	55	-	3
70	70	M12	-	55	-	3
70	70	M10x25	-	55	-	4
70	70	M12x42	-	55	-	4
75	20	M10x28	-	55	-	4
75	20	M10x42	-	55	-	4
75	20	M12x37	-	55	-	4
75	20	M12x38	-	55	-	4

Note: Thread 2 = Thread 1 unless otherwise specified. / Poznámka: Závít 2 = Závít 1 pokud není uvedeno jinak. / Заметка: Винт 2 = Винт 1, если не установлено иначе.

Type 1



Type 2



Type 3



Type 4



Type 5



D ₁	H ₁	Thread 1 Závit 1 Винт 1 (Gxh)	Thread 2 Závit 2 Винт 2 (Gxh)	ShA ftop A	Shape Tvar Модель	Type Typ Тип
75	20	M12x47	-	55	-	4
75	20	M12	-	55	-	5
75	25	M8x28	-	55	-	1
75	25	M10x28	-	55	-	1
75	25	M12x37	-	55	-	1
75	25	M12x37	M12x22	55	-	1
75	25	M12x47	-	55	-	1
75	25	M12x50	-	55	-	1
75	25	M10x27	-	55	-	2
75	25	M10x28	-	55	-	2
75	25	M12x37	-	55	-	2
75	25	M10x20	-	55	-	4
75	25	M10x25	-	55	-	4
75	25	M10x28	-	55	-	4
75	25	M10x33	-	55	-	4
75	25	M10x37	-	55	-	4
75	25	M12x12	-	55	-	4
75	25	M12x25	-	55	-	4
75	25	M12x37	-	55	-	4
75	25	M10	-	55	-	5
75	25	M12	-	55	-	5
75	25	M16	-	55	-	5
75	30	M12x28	-	55	-	1
75	30	M12x37	-	55	-	1
75	30	M12x37	-	55	-	2
75	30	M8	-	55	-	3
75	30	M12	-	55	-	3
75	30	M12x33	-	55	-	4
75	30	M12x37	-	55	-	4
75	30	M12	-	55	-	5
75	35	M10x28	-	55	-	1
75	35	M10x33	-	55	-	1
75	35	M12x37	-	55	-	1
75	35	M12x37	-	55	-	2
75	35	M10	-	55	-	3
75	35	M12	-	55	-	3
75	35	M10x20	-	55	-	4
75	35	M12x37	-	55	-	4
75	35	M12x40	-	55	-	4
75	35	M12	-	55	-	5
75	40	M8x18	-	55	-	1
75	40	M10x28	-	55	-	1
75	40	M10x37	-	55	-	1

D ₁	H ₁	Thread 1 Závit 1 Винт 1 (Gxh)	Thread 2 Závit 2 Винт 2 (Gxh)	ShA ft op A	Shape Tvar Модель	Type Typ Тип
75	40	M12x12	-	55	-	1
75	40	M12x27	-	55	-	1
75	40	M12x33	-	55	-	1
75	40	M12x37	-	55	-	1
75	40	M12x40	-	55	-	1
75	40	M10x22	-	55	-	2
75	40	M10x28	-	55	-	2
75	40	M10x38	-	55	-	2
75	40	M12x18	-	55	-	2
75	40	M12x22	-	55	-	2
75	40	M12x25	-	55	-	2
75	40	M12x27	-	55	-	2
75	40	M12x33	-	55	-	2
75	40	M12x37	-	55	-	2
75	40	M12x38	-	55	-	2
75	40	M10	-	55	-	3
75	40	M12	-	55	-	3
75	40	M16	-	55	-	3
75	40	M8x30	-	55	-	4
75	40	M10x15	-	55	-	4
75	40	M10x23	-	55	-	4
75	40	M10x28	-	55	-	4
75	40	M12x27	-	55	-	4
75	40	M12x33	-	55	-	4
75	40	M12x37	-	55	-	4
75	40	M12	-	55	-	5
75	40	M16	-	55	-	5
75	45	M10x28	-	55	-	1
75	45	M12x37	-	55	-	1
75	45	M10x28	-	55	-	2
75	45	M10x30	-	55	-	2
75	45	M10x68	-	55	-	2
75	45	M12x23	-	55	-	2
75	45	M12x24	-	55	-	2
75	45	M12x33	-	55	-	2
75	45	M12x37	-	55	-	2
75	45	M10	-	55	-	3
75	45	M12	-	55	-	3
75	45	M10x28	-	55	-	4
75	45	M12x27	-	55	-	4
75	45	M12x37	-	55	-	4
75	45	M10	-	55	-	5
75	45	M12	-	55	-	5

Type 1

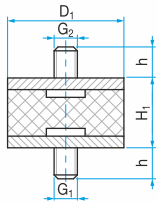

Type 2

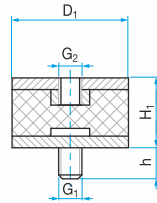

Type 3

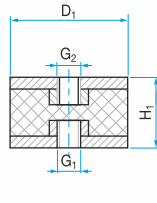

Type 4

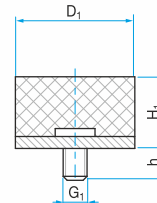

Type 5

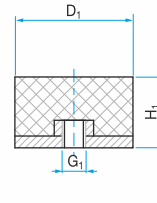

D ₁	H ₁	Thread 1 Závit 1 Винт 1 (Gxh)	Thread 2 Závit 2 Винт 2 (Gxh)	ShA ftop A	Shape Tvar Модель	Type Typ Тип
75	50	M10x28	-	55	-	1
75	50	M12x17	-	55	-	1
75	50	M12x28	-	55	-	1
75	50	M12x37	-	55	-	1
75	50	M16x37	-	55	-	1
75	50	M10x20	-	55	-	2
75	50	M10x23	-	55	-	2
75	50	M10x25	-	55	-	2
75	50	M10x28	-	55	-	2
75	50	M12x17	-	55	-	2
75	50	M12x28	-	55	-	2
75	50	M12x33	-	55	-	2
75	50	M12x37	-	55	-	2
75	50	M10	-	55	-	3
75	50	M12	-	55	-	3
75	50	M16	-	55	-	3
75	50	M12x37	-	55	-	4
75	50	M12	-	55	-	5
75	52	M12x37	-	55	-	1
75	52	M12x37	-	55	-	4
75	55	M12x28	-	55	-	1
75	55	M12x30	-	55	-	1
75	55	M12x30	M20x100	55	-	1
75	55	M12x30	M20x125	55	-	1
75	55	M12x37	-	55	-	1
75	55	M10x38	-	55	-	2
75	55	M12x25	-	55	-	2
75	55	M12x37	-	55	-	2
75	55	M16x37	-	55	-	2
75	55	M10	-	55	-	3
75	55	M12	-	55	-	3
75	55	M14	-	55	-	3
75	55	M16	-	55	-	3
75	55	M10x28	-	55	-	4
75	55	M10x37	-	55	-	4
75	55	M12x37	-	55	-	4
75	55	M12	-	55	-	5
75	60	M12x37	-	55	-	1
75	60	M10x28	-	55	-	2
75	60	M12x33	-	55	-	2
75	60	M12x37	-	55	-	2
75	60	M12	-	55	-	3
75	60	M10x33	-	55	-	4

D ₁	H ₁	Thread 1 Závit 1 Винт 1 (Gxh)	Thread 2 Závit 2 Винт 2 (Gxh)	ShA ftop A	Shape Tvar Модель	Type Typ Тип
75	60	M12x33	-	55	-	4
75	60	M12x37	-	55	-	4
75	65	M12 - 55	-	5	-	
75	70	M12x23	-	55	-	1
75	70	M12x30	-	55	-	1
75	70	M12x37	-	55	-	1
75	70	M12x37	-	55	-	2
75	70	M12	-	55	-	3
75	70	M12x37	-	55	-	4
75	100	M12x37	-	55	-	1
75	100	M12x37	-	55	-	2
75	100	M12x37	-	55	-	4
80	17	M10x28	-	55	-	1
80	17	M12x37	-	55	-	1
80	18	M10x28	-	55	-	1
80	30	M12x28	-	55	-	1
80	30	M14x37	-	55	-	1
80	30	M14x47	-	55	-	1
80	30	M12x28	-	55	-	2
80	30	M12x37	-	55	-	2
80	30	M14x37	-	55	-	4
80	30	M14x47	-	55	-	4
80	37	M12x23	-	60	68.12	1
80	40	M14x37	-	55	-	1
80	40	M12x33	-	55	-	4
80	40	M12x35	-	55	-	4
80	40	M12x37	-	55	-	4
80	40	M14x37	-	55	-	4
80	40	M12	-	55	-	5
80	50	M10x27	-	55	-	1
80	60	M12x37	-	55	-	1
80	60	M10x28	-	55	-	2
80	60	M14x37	-	55	-	4
80	70	M12x47	-	55	-	1
80	70	M14x37	-	55	-	1
80	70	M12x37	-	55	-	2
80	70	M14x37	-	55	-	4
80	75	M12x37	-	55	-	1
80	80	M12x36	-	55	-	1
80	80	M12x37	-	55	-	1
80	80	M16x37	-	55	-	1
80	80	M16x41	-	55	-	1
80	80	M16x47	-	55	-	1

Note: Thread 2 = Thread 1 unless otherwise specified. / Poznámka: Závit 2 = Závit 1 pokud není uvedeno jinak. / Заметка: Винт 2 = Винт 1, если не установлено иначе.

Type 1



Type 2



Type 3



Type 4



Type 5



D ₁	H ₁	Thread 1 Závit 1 Винт 1 (Gxh)	Thread 2 Závit 2 Винт 2 (Gxh)	ShA Шоп А	Shape Tvar Модель	Type Typ Тип
80	80	M16x50	-	55	-	1
80	80	M12x12	-	55	-	2
80	80	M16x41	-	55	-	2
80	80	M16	-	55	-	3
80	80	M12x36	-	55	-	4
80	80	M12	-	55	-	5
90	60	M12	-	55	-	5
90	60	M12x28	-	55	-	4
90	60	M12x30	-	55	-	4
100	25	M12x25	M12x47	55	-	1
100	25	M16x41	-	55	-	1
100	25	M16x45	-	55	-	1
100	25	M10x28	-	55	-	4
100	25	M16x41	-	55	-	4
100	25	M16x46	-	55	-	4
100	30	M16x41	-	55	-	1
100	30	M16x45	-	55	-	1
100	30	M16x50	-	55	-	1
100	30	M16x41	-	55	-	2
100	30	M12x33	-	55	-	4
100	30	M12x37	-	55	-	4
100	30	M16x20	-	55	-	4
100	30	M16x41	-	55	-	4
100	30	M16	-	55	-	5
100	35	M16x41	-	55	-	1
100	35	M16	-	55	-	3
100	40	M12x37	-	55	-	1
100	40	M14x25	-	50	37.12	1
100	40	M16x27	-	55	-	1
100	40	M16x38	-	55	-	1
100	40	M16x41	-	55	-	1
100	40	M12x18	-	55	-	2
100	40	M12x36	-	55	-	2
100	40	M12x37	-	55	-	2
100	40	M16x16	-	55	-	2
100	40	M16x26	-	55	-	2
100	40	M16x32	-	55	-	2
100	40	M16x36	-	55	-	2
100	40	M16x41	-	55	-	2
100	40	M16x42	-	55	-	2
100	40	M16x45	-	55	-	2
100	40	M16x46	-	55	-	2
100	40	M16x47	-	55	-	2

D ₁	H ₁	Thread 1 Závit 1 Винт 1 (Gxh)	Thread 2 Závit 2 Винт 2 (Gxh)	ShA Шоп А	Shape Tvar Модель	Type Typ Тип
100	40	M16	-	55	-	3
100	40	M10x28	-	55	-	4
100	40	M12x37	-	55	-	4
100	40	M12x41	-	55	-	4
100	40	M16x41	-	55	-	4
100	40	M16x43	-	55	-	4
100	40	M12	-	55	-	5
100	40	M16	-	55	-	5
100	45	M12x30	-	55	-	1
100	45	M12x42	-	55	-	1
100	45	M16x41	-	55	-	2
100	45	M16	-	55	-	3
100	50	M12x37	-	55	-	1
100	50	M12x42	-	55	-	1
100	50	M14x25	-	50	96.12	1
100	50	M14x25	-	60	96.12	1
100	50	M16x26	-	55	-	1
100	50	M16x41	-	55	-	1
100	50	M20x50	-	55	-	1
100	50	M12x37	-	55	-	2
100	50	M16x41	-	55	-	2
100	50	M12	-	55	-	3
100	50	M12	-	60	163.12	3
100	50	M16	-	55	-	3
100	50	M12x37	-	55	-	4
100	50	M16x41	-	55	-	4
100	50	M16x46	-	55	-	4
100	50	M16x56	-	55	-	4
100	50	M16	-	55	-	5
100	55	M12x25	-	55	-	1
100	55	M12x37	-	55	-	1
100	55	M16x41	-	55	-	1
100	55	M16x45	-	55	-	1
100	55	M16x46	-	55	-	1
100	55	M10x44	-	55	-	2
100	55	M16x26	-	55	-	2
100	55	M16x41	-	55	-	2
100	55	M16x43	-	55	-	2
100	55	M16x44	-	55	-	2
100	55	M16x45	-	55	-	2
100	55	M10	-	55	-	3
100	55	M12	-	55	-	3
100	55	M14	-	55	-	3

Type 1

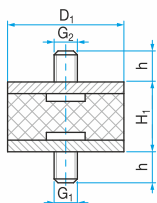

Type 2

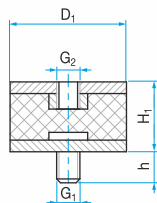

Type 3

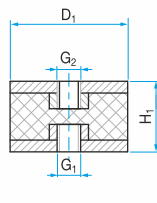

Type 4

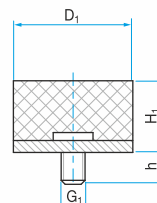

Type 5

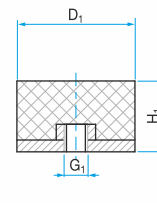

D ₁	H ₁	Thread 1 Závit 1 Винт 1 (Gxh)	Thread 2 Závit 2 Винт 2 (Gxh)	ShA Шоп А	Shape Tvar Модель	Type Typ Тип
100	55	M16	-	55	-	3
100	55	M16x41	-	55	-	4
100	55	M16	-	55	-	5
100	60	M12x25	-	55	-	1
100	60	M16x21	-	55	-	1
100	60	M16x26	-	55	-	1
100	60	M16x27	-	55	-	1
100	60	M16x41	-	55	-	1
100	60	M16x44	-	55	-	1
100	60	M16x46	-	55	-	1
100	60	M16x41	-	55	-	2
100	60	M16	-	55	-	3
100	60	M16x41	-	55	-	4
100	60	M16	-	55	-	5
100	65	M12x25	-	40	109.12	1
100	65	M12x25	-	50	109.12	1
100	65	M12x25	-	60	109.12	1
100	65	M12x28	-	55	-	1
100	65	M12x37	-	55	-	1
100	65	M16x41	-	55	-	4
100	70	M16x25	-	55	-	1
100	70	M16x41	-	55	-	1
100	70	M16x52	-	55	-	1
100	70	M10x28	-	55	-	2
100	70	M12x37	-	55	-	2
100	70	M16x41	-	55	-	2
100	70	M12x37	-	55	-	4
100	70	M16 - 55	-	5	-	-
100	75	M16x41	-	55	-	1
100	75	M16x46	-	55	-	1
100	75	M16x51	-	55	-	1
100	75	M16x31	-	55	-	2
100	75	M16x41	-	55	-	2
100	75	M16	-	55	-	3
100	75	M16x41	-	55	-	4
100	75	M16x47	-	55	-	4
100	75	M16	-	55	-	5
100	80	M16x41	-	55	-	1
100	80	M16x46	-	55	-	1
100	80	M16x25	-	55	-	2
100	80	M16x46	-	55	-	2
100	80	M16x52	-	55	-	2
100	80	M16x41	-	55	-	4

D ₁	H ₁	Thread 1 Závit 1 Винт 1 (Gxh)	Thread 2 Závit 2 Винт 2 (Gxh)	ShA Шоп А	Shape Tvar Модель	Type Typ Тип
100	80	M20	-	55	-	5
100	100	M12x37	-	55	-	1
100	100	M16x41	-	55	-	1
100	100	M16x41	-	55	-	2
100	100	M12	-	55	-	3
100	100	M16	-	55	-	3
100	100	M12x23	-	55	-	4
100	100	M12x37	-	55	-	4
100	100	M16x41	-	55	-	4
100	100	M16	-	55	-	5
125	40	M16x37	-	55	-	1
125	40	M16x75	M16x37	55	-	1
125	55	M16x41	-	55	-	2
125	55	M16	-	55	-	3
125	55	M16x41	-	55	-	4
125	60	M16x41	-	55	-	1
125	75	M16x41	-	55	-	1
125	75	M16x41	-	55	-	2
125	90	M16x41	-	55	-	1
125	90	M16	-	55	-	5
125	100	M16x41	-	55	-	1
125	100	M16	-	55	-	5
125	125	M16x41	-	55	-	4
150	45	M16x41	-	55	-	1
150	45	M16	-	55	-	3
150	45	M16x41	-	55	-	4
150	45	M16	-	55	-	5
150	50	M16x100	M16x120	55	-	1
150	50	M16x41	-	55	-	1
150	50	M16x45	-	55	-	1
150	50	M16x41	-	55	-	2
150	50	M16	-	55	-	3
150	50	M20	-	55	-	3
150	50	M16x41	-	55	-	4
150	50	M16	-	55	-	5
150	55	M16x41	-	55	-	1
150	55	M16x41	-	55	-	2
150	55	M16	-	55	-	3
150	55	M20	-	55	-	3
150	55	M16x41	-	55	-	4
150	55	M16	-	55	-	5
150	60	M16x41	-	55	-	1
150	60	M16x80	M16x37	55	-	1

Note: Thread 2 = Thread 1 unless otherwise specified. / Poznámka: Závit 2 = Závit 1 pokud není uvedeno jinak. / фаметка: Винт 2 = Винт 1, если не установлено иначе.

Type 1



Type 2



Type 3



Type 4



Type 5



D ₁	H ₁	Thread 1 Závit 1 Винт 1 (Gxh)	Thread 2 Závit 2 Винт 2 (Gxh)	ShA Шор А	Shape Tvar Модель	Type Typ Тип
150	60	M16x41	-	55	-	2
150	60	M20x45	-	55	-	2
150	60	M16	-	55	-	3
150	60	M20 - 55	-	3	-	
150	60	M16x41	-	55	-	4
150	60	M16 - 55	-	5	-	
150	75	M16x41	-	55	-	1
150	75	M20x41	-	55	-	1
150	75	M20x45	-	55	-	1
150	75	M16x41	-	55	-	2
150	75	M20x41	-	55	-	2
150	75	M20x61	-	55	-	2
150	75	M16	-	55	-	3
150	75	M20	-	55	-	3
150	75	M16x16	-	55	-	4
150	75	M16x41	-	55	-	4
150	75	M20x41	-	55	-	4
150	75	M20x45	-	55	-	4
150	75	M16 - 55	-	5	-	
150	75	M20 - 55	-	5	-	
150	100	M16x41	-	55	-	1
150	100	M20x41	-	55	-	1
150	100	M20x45	-	55	-	1
150	100	M20x46	-	55	-	1
150	100	M16x41	-	55	-	2
150	100	M16	-	55	-	3
150	100	M20	-	55	-	3
150	100	M20	-	55	-	5
150	120	M20x41	-	55	-	2
150	120	M16x41	-	55	-	4
150	150	M16x41	-	55	-	1
200	100	M16x41	-	55	-	1
200	100	M20x50	-	55	-	1
200	100	M20x41	-	55	-	2
200	100	M20x50	-	55	-	2
200	100	M16	-	55	-	3
200	100	M20	-	55	-	3
200	100	M24	-	55	-	3
200	100	M20x50	-	55	-	4
200	100	M20	-	55	-	5

LOAD CHARACTERISTICS ζ TYPE 1
 ZATĚŽOVACÍ CHARAKTERISTIKY ζ TYP 1
 НАГРУЗОЧНЫЕ ХАРАКТЕРИСТИКИ ζ ТИП 1

44

D ₁	H ₁	f (mm)	F _v (daN)		
			43Sh	57Sh	68Sh
8	8	0,4	0,7	1,6	4,5
		0,8	1,5	3,5	9
		1,2	2,5	5,5	14,5
10	10	0,6	1,2	2,5	7
		1,2	2,5	6	14,5
		1,6	3,5	8	20,5
15	8	0,4	3,5	7,5	21
		0,8	7,5	15,5	45
		1,2	12	25	74,5
15	15	0,8	2	4,5	12,5
		1,5	4	9,5	22,5
		2,5	7,5	17	40
20	15	1	5,5	13,5	28
		2	11,5	28,5	60
		2,5	15	37	77,5
20	20	1	3,5	8,5	18
		2,5	9	22,5	47,5
		3,5	13	32,5	70
25	15	1	9,5	23	48
		1,5	14,5	36	74,5
		2,5	26	64,5	134
25	20	1	5,5	14	29,5
		2,5	15	37	78
		3,5	22	54	114,5
30	15	1	16,5	29	89
		2	46	80	195
		2,5	61	104,5	256
30	20	1	10,5	21	49
		2,5	29	57	131,5
		3,5	43	84	194,5
30	30	1,5	8	17,5	39,5
		3	17	36,5	81,5
		5,3	31,5	67,5	152
40	30	1,5	16	33,5	74,5
		3	33	67	155,5
		5,3	62	130	291
40	40	2	13,5	30,5	67
		5	36	78	176,5
		7	53	116	256,5
50	20	1	44	89,5	183
		2	94,5	191	390
		3	153,5	308,5	627

D ₁	H ₁	f (mm)	F _v (daN)		
			43Sh	57Sh	68Sh
50	30	1,5	27,5	60	126
		3	58	125,5	263
		4,5	91,5	198	414,5
50	40	3	35	78,5	167
		6	74,5	167	354
		8	104,5	232,5	493
70	45	2	46	101	212,5
		5	122,5	210	563
		8	210,5	458	961
75	40	2	69	147,5	307,5
		4	145,5	247,5	646,5
		7	279,5	590,5	1227,5
75	55	1,5	29	64,5	137
		4,5	90,5	201,5	427,5
		7,5	158,5	352	743,5
100	40	2	176	358	734
		4	378,5	765	1560
		6	614	1233,5	2500
100	55	3	130	280	586,5
		6	276,5	591,5	1234
		9	442,5	942,5	1956
100	60	3	110	234	504,5
		6	231,5	502	1054
		10,5	440	949	1984,5
100	75	6	155	346	734
		12	333,5	741	1568
		16,5	487,5	1077,5	2279
150	55	3	414,5	915	1713,5
		6	892	1969,5	3659,5
		9	1452	3204,5	5902,5
150	60	3	336	745	1422,5
		7,5	925	2046,5	3771,5
		10,5	1391,5	3075	5775
150	75	4	282,5	634,5	1259,5
		10	771	1726	3401
		14	1152	2573,5	5042,5
200	100	6	540,5	1204	2504,5
		12	1150	2550	5302
		18	1846,5	4073,5	8467

LOAD CHARACTERISTICS ζ TYPE 2
 ZATĚŽOVACÍ CHARAKTERISTIKY ζ TYP 2
 НАГРУЗОЧНЫЕ ХАРАКТЕРИСТИКИ ζ ТИП 2

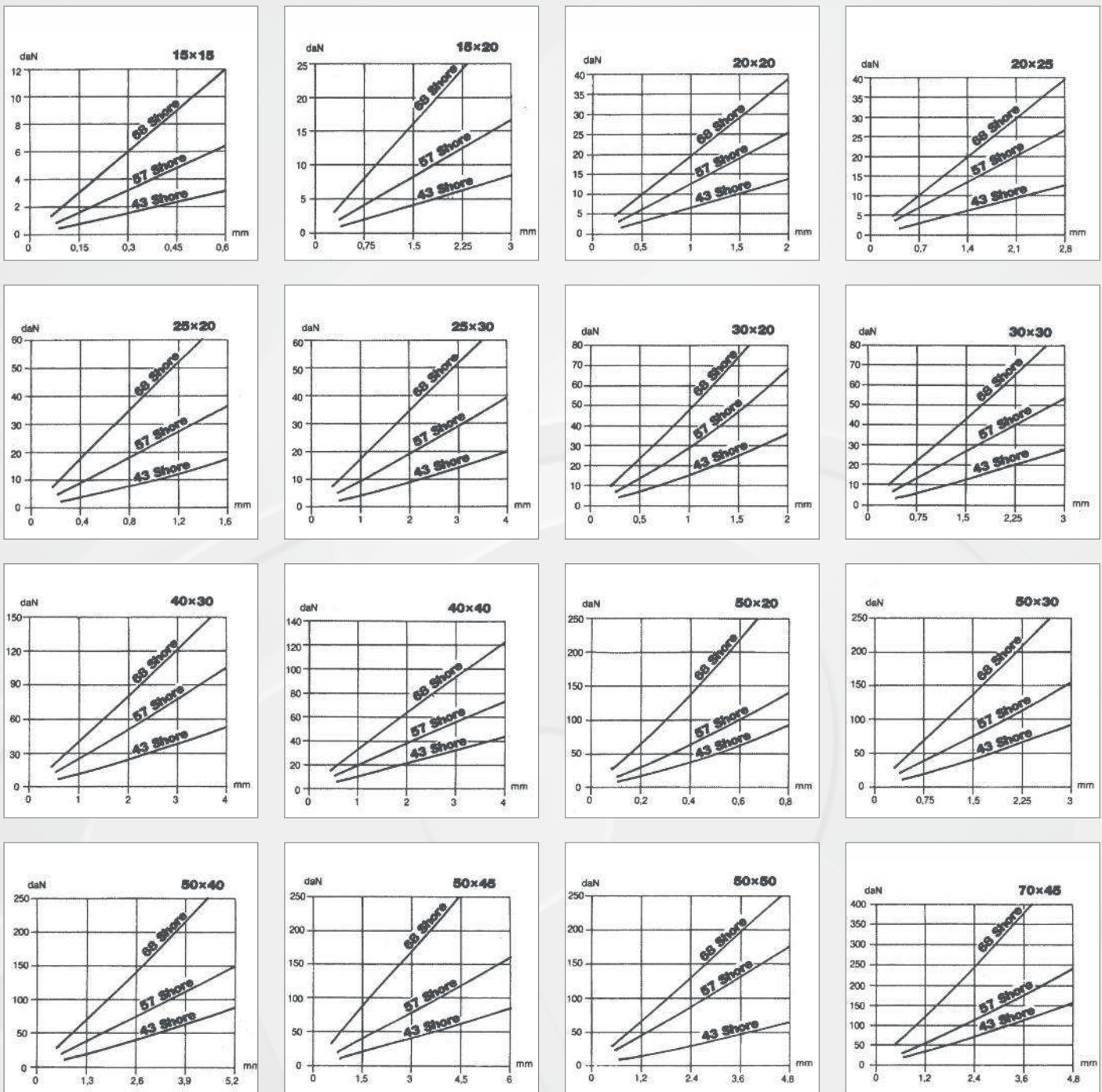

LOAD CHARACTERISTICS ζ TYPE 2
 ZATĚŽOVACÍ CHARAKTERISTIKY ζ TYP 2
 НАГРУЗОЧНЫЕ ХАРАКТЕРИСТИКИ ζ ТИП 2

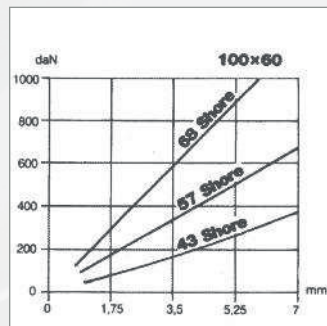
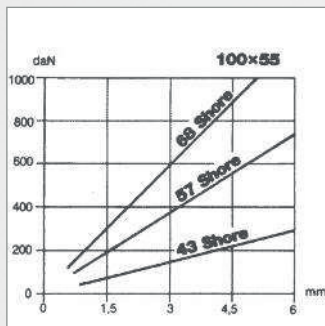
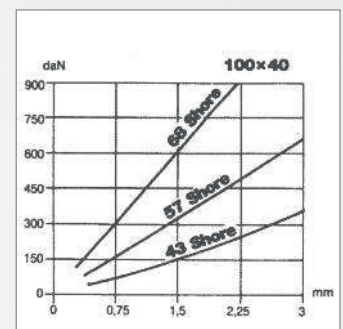
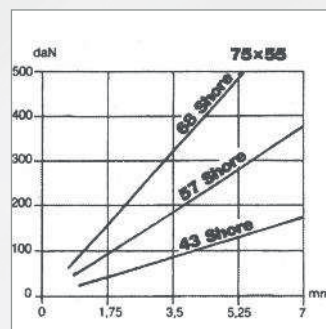
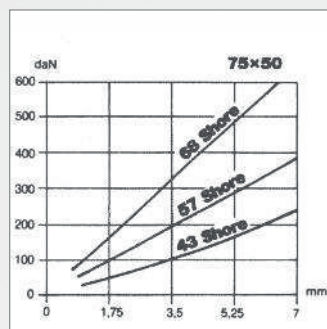
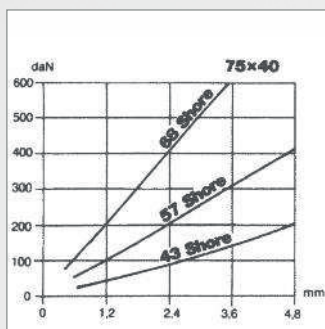

LOAD CHARACTERISTICS ζ TYPE 3
 ZATĚŽOVACÍ CHARAKTERISTIKY ζ TYP 3
 НАГРУЗОЧНЫЕ ХАРАКТЕРИСТИКИ ζ ТИП 3

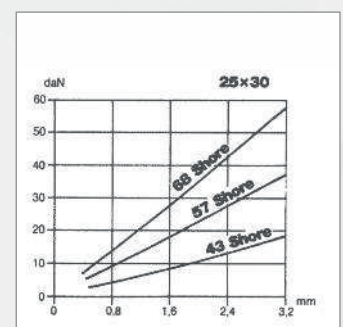
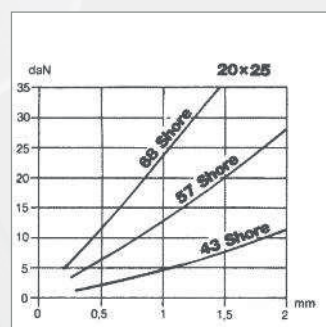
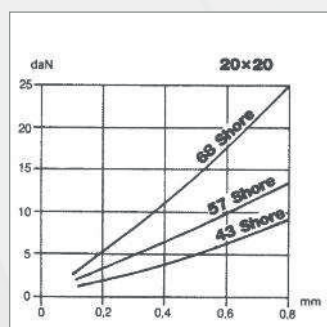
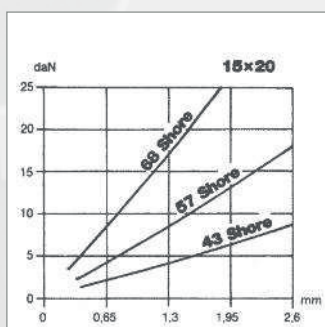

LOAD CHARACTERISTICS ζ TYPE 3
 ZATĚŽOVACÍ CHARAKTERISTIKY ζ TYP 3
 НАГРУЗОЧНЫЕ ХАРАКТЕРИСТИКИ ζ ТИП 3



CYLINDRICAL VIBRATION DAMPERS NONSTANDARD - FULL

VÁLCOVÉ PRUŽINY NESTANDARDNÍ - PLNĚ

ЦИЛИНДРИЧЕСКИЕ АМОТИФТОРЫ НЕСТАНДАРТНЫЕ - СКВОФНЫЕ

Type TP1

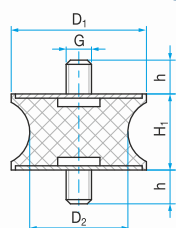

Type TP2

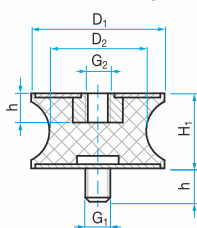

Type TP3

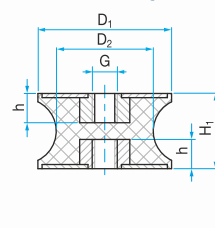

48

D ₁	D ₂	H ₁	Thread 1(Gxh) Závit 1 (Gxh) Винт 1 (Gxh)	Thread 2(Gxh) Závit 2 (Gxh) Винт 2 (Gxh)	Type Typ Тип
10	4,5	8	M 3x 6	-	TP1
10	4,5	8	M 3x 6	M 3x 3	TP2
10	4,5	8	M 3x 3	-	TP3
10	8	10	M 4x10	-	TP1
10	8	10	M 4x10	M 4x 4	TP2
10	8	10	M 4x 4	-	TP3
15	8,5	15	M 4x10	-	TP1
15	8,5	15	M 4x10	M 4x 4	TP2
15	8,5	15	M 4x 4	-	TP3
15	12	15	M 4x10	-	TP1
15	12	15	M 4x10	M 4x 4	TP2
15	12	15	M 4x 4	-	TP3
20	12	30	M 6x18	-	TP1
20	12	30	M 6x18	M 6x 6	TP2
20	12	30	M 6x 6	-	TP3
20	14	15	M 4x10	-	TP1
20	14	15	M 4x10	M 4x 4	TP2
20	14	15	M 4x 4	-	TP3
20	14	19	M 6x18	-	TP1
20	14	19	M 6x18	M 6x 6	TP2
20	14	19	M 6x 6	-	TP3
20	14	30	M 4x10	-	TP1
20	14	30	M 4x10	M 4x 4	TP2
20	14	30	M 4x 4	-	TP3
25	18	20	M 8x23	-	TP1
25	18	20	M 8x23	M 8x 8	TP2
25	18	20	M 8x 8	-	TP3
25	20	20	M 6x10	-	TP1
25	20	20	M 6x10	M 6x 6	TP2
25	20	20	M 6x 6	-	TP3
30	18	25	M 6x15	-	TP1
30	18	25	M 6x15	M 6x 6	TP2
30	18	25	M 6x 6	-	TP3
30	19,5	41	M 8x20	-	TP1
30	19,5	41	M 8x20	M 8x 8	TP2
30	19,5	41	M 8x 8	-	TP3
30	22	20	M 8x23	-	TP1
30	22	20	M 8x23	M 8x 8	TP2
30	22	20	M 8x 8	-	TP3
30	25	20	M 8x23	-	TP1
30	25	20	M 8x23	M 8x 8	TP2
30	25	20	M 8x 8	-	TP3
40	20	48	M 8x23	-	TP1
40	20	48	M 8x23	M 8x 8	TP2

D ₁	D ₂	H ₁	Thread 1(Gxh) Závit 1 (Gxh) Винт 1 (Gxh)	Thread 2(Gxh) Závit 2 (Gxh) Винт 2 (Gxh)	Type Typ Тип
40	20	48	M 8x 8	-	TP3
40	25	30	M 8x23	-	TP1
40	25	30	M 8x23	M 8x 8	TP2
40	25	30	M 8x 8	-	TP3
40	33	30	M 8x23	-	TP1
40	33	30	M 8x23	M 8x 8	TP2
40	33	30	M 8x 8	-	TP3
46	40	25	M10x28	-	TP1
46	40	25	M10x28	M10x10	TP2
46	40	25	M10x10	-	TP3
50	42	30	M10x28	-	TP1
50	42	30	M10x28	M10x10	TP2
50	42	30	M10x10	-	TP3
55	44	45	M 8x28	-	TP1
55	44	45	M 8x28	M 8x 8	TP2
55	44	45	M 8x 8	-	TP3
57	25	44	M10x28	-	TP1
57	25	44	M10x28	M10x10	TP2
57	25	44	M10x10	-	TP3
57	25	45	M 8x20	-	TP1
57	25	45	M 8x20	M 8x 8	TP2
57	25	45	M 8x 8	-	TP3
57	44	45	M10x28	-	TP1
57	44	45	M10x28	M10x10	TP2
57	44	45	M10x10	-	TP3
57	45	44	M10x28	-	TP1
57	45	44	M10x28	M10x10	TP2
57	45	44	M10x10	-	TP3
60	49	60	M10x28	-	TP1
60	49	60	M10x28	M10x10	TP2
60	49	60	M10x10	-	TP3
70	45	53	M12x28	-	TP1
70	45	53	M12x28	M12x12	TP2
70	45	53	M12x12	-	TP3
95	80	75	M16x41	-	TP1
95	80	75	M16x41	M16x16	TP2
95	80	75	M16x16	-	TP3
180	148	75	M20x34	-	TP1
180	148	75	M20x34	M20x20	TP2
180	148	75	M20x20	-	TP3
180	150	75	M20x45	-	TP1
180	150	75	M20x45	M20x20	TP2
180	150	75	M20x20	-	TP3

Note: Thread 2 = Thread 1 unless otherwise specified. / Poznámka: Závit 2 = Závit 1 pokud není uvedeno jinak. / фаметка: Винт 2 = Винт 1, если не установлено иначе.

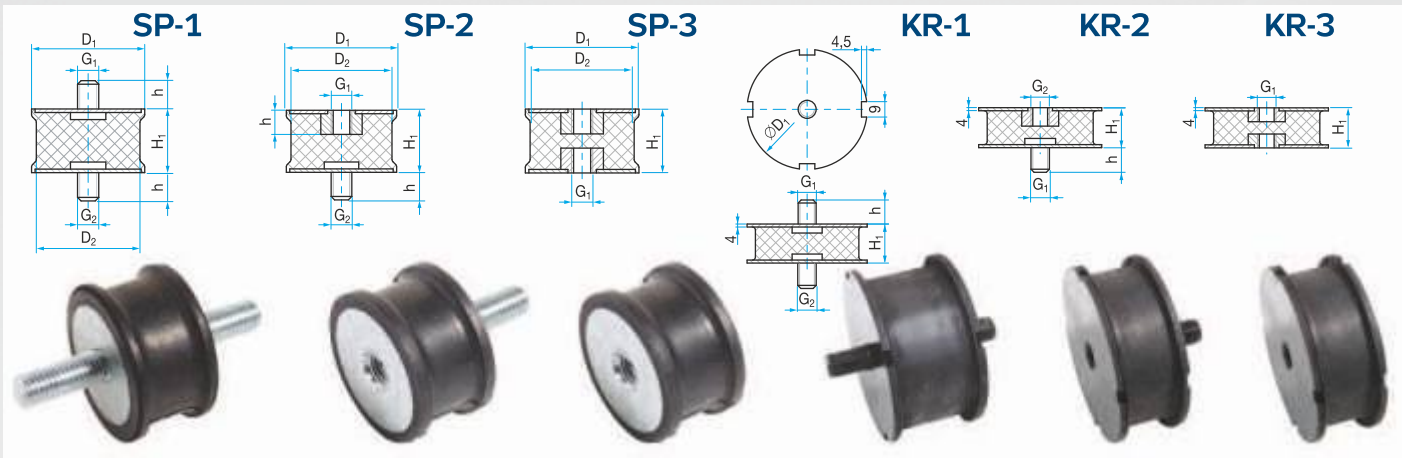

D ₁	D ₂	H ₁	Thread 1(Gxh) Závit 1 (Gxh) Винт 1 (Gxh)	Thread 2(Gxh) Závit 2 (Gxh) Винт 2 (Gxh)	Type Typ Тип
26	22	22	M8x10	M8x18	SP-1
26	22	22	M8	M8x18	SP-2
26	22	22	M8	M8	SP-3
40	35	28	M10x16	M10x20	SP-1
40	35	28	M10	M10x20	SP-2
40	35	28	M10	M10	SP-3
6	40	25	M10x28	M10x28	SP-1
46	40	25	M10	M10x28	SP-2
46	40	25	M10	M10	SP-3
75	70	40	M12x37	M12x37	SP-1
75	70	40	M12	M12x37	SP-2
75	70	40	M12	M12	SP-3
100	95	55	M16x41	M16x41	SP-1
100	95	55	M16	M16x41	SP-2
100	95	55	M16	M16	SP-3
100	95	75	M16x45	M16x45	SP-1
100	95	75	M16	M16x45	SP-2
100	95	75	M16	M16	SP-3

D ₁	H ₁	Thread 1(Gxh) Závit 1 (Gxh) Винт 1 (Gxh)	Thread 2(Gxh) Závit 2 (Gxh) Винт 2 (Gxh)	Type Typ Тип
105	55	M16x30	M16x30	KR-1
105	40	M16x30	M16x25	KR-1
105	55	M16x30	M16	KR-2
105	40	M16x30	M16	KR-2
105	55	M16	M16	KR-3
105	40	M16	M16	KR-3

CYLINDRICAL VIBRATION DAMPERS NONSTANDARD - PERFORMATED
 VÁLCOVÉ PRUŽINY NESTANDARDNÍ - PRŮCHOZÍ
 ЦИЛИНДРИЧЕСКИЕ АМОТИФТОРЫ НЕСТАНДАРТНЫЕ - МАССИВНЫЕ

Type GH

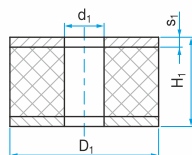

Type GK

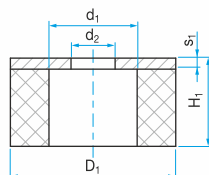

Type GP

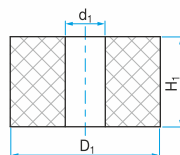

Type IS

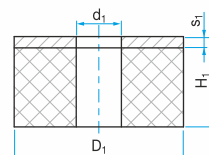

Type RB

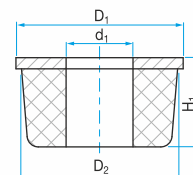

D ₁	D ₂	d ₁	d ₂	H ₁	S ₁	Туре Тур Тип
15	-	6	-	25	2	GH
20	-	6	-	25	2	GH
40	-	13	-	20	3	GH
40	-	13	-	30	3	GH
40	-	13	-	40	3	GH
50	-	13	-	20	3	GH
50	-	17	-	40	3	GH
50	-	17	-	50	3	GH
50	-	21	-	15	3	GH
50	-	21	-	30	3	GH
60	-	21	-	50	4	GH
75	-	25	-	55	3	GH
80	-	21	-	30	3	GH
100	-	21	-	40	4	GH
100	-	31	-	40	4	GH
100	-	33	-	75	5	GH
120	-	41	-	40	5	GH
120	-	51	-	40	5	GH
150	-	51	-	100	6	GH
200	-	32	-	100	8	GH
200	-	61	-	100	8	GH
30	-	16	9	16	3	GK
40	-	16	9	16	3	GK
40	-	17	9	20	3	GK
50	-	20	11	16	3	GK
50	-	22	11	20	3	GK
60	-	25	25	18	3	GK
60	-	25	11	20	4	GK
75	-	30	13	25	6	GK
80	-	32	13	20	4	GK
100	-	40	13	25	6	GK
100	-	60	33	30	6	GK
125	-	50	17	25	6	GK
8,5	-	3,2	-	3,5	-	GP
13	-	6,5	-	12	-	GP
17,5	-	9	-	16	-	GP
19	-	13	-	19	-	GP
20	-	8,5	-	15	-	GP
25	-	8,5	-	25	-	GP
25	-	10,5	-	0,25	-	GP
25	-	10,5	-	15	-	GP

D ₁	D ₂	d ₁	d ₂	H ₁	S ₁	Туре Тур Тип
28	-	8	-	16	-	GP
28	-	10,5	-	50	-	GP
30	-	16	-	40	-	GP
32	-	13,5	-	32	-	GP
40	-	0,9	-	30	-	GP
40	-	12	-	25	-	GP
40	-	12	-	35	-	GP
40	-	12	-	65	-	GP
40	-	13	-	30	-	GP
40	-	13,5	-	32	-	GP
40	-	13,5	-	40	-	GP
40	-	13,5	-	40	-	GP
40	-	13,5	-	50	-	GP
40	-	17	-	30	-	GP
47	-	20	-	50	-	GP
48	-	17	-	100	-	GP
50	-	10	-	45	-	GP
50	-	14	-	80	-	GP
50	-	17	-	25	-	GP
50	-	17	-	32	-	GP
50	-	17	-	40	-	GP
50	-	17	-	50	-	GP
50	-	17	-	63	-	GP
50	-	17	-	80	-	GP
50	-	20	-	38	-	GP
50	-	24	-	50	-	GP
50	-	24,8	-	50	-	GP
53	-	32,5	-	100	-	GP
58	-	17	-	100	-	GP
60	-	20	-	40	-	GP
70	-	40	-	40	-	GP
75	-	18	-	40	-	GP
80	-	15	-	50	-	GP
80	-	20	-	27	-	GP
80	-	20	-	40	-	GP
80	-	21	-	30	-	GP
80	-	21	-	100	-	GP
80	-	25	-	40	-	GP
80	-	25	-	82	-	GP
80	-	30	-	35	-	GP
80	-	40	-	30	-	GP

Type GH



Type GK



Type GP



Type IS



Type RB



D ₁	D ₂	d ₁	d ₂	H ₁	S ₁	Туре Тур Тип
90	-	30	-	45	-	GP
100	-	21	-	40	-	GP
100	-	25	-	40	-	GP
100	-	25	-	70	-	GP
100	-	26	-	40	-	GP
100	-	30	-	35	-	GP
100	-	33	-	40	-	GP
100	-	33	-	75	-	GP
100	-	40	-	70	-	GP
100	-	70	-	40	-	GP
120	-	25	-	40	-	GP
120	-	40	-	40	-	GP
120	-	50	-	40	-	GP
125	-	35	-	125	-	GP
125	-	50	-	125	-	GP
150	-	45	-	180	-	GP
150	-	51	-	100	-	GP
160	-	33	-	160	-	GP
200	-	33	-	200	-	GP
200	-	61	-	100	-	GP
250	-	60	-	200	-	GP
40	-	10	-	10	2	IS
62	-	6	-	14	3	IS
80	-	30	-	21	2	IS
100	-	19	-	56	3	IS
100	-	21	-	40	4	IS
100	-	25	-	40	4	IS
100	-	30	-	21	4	IS
100	-	30	-	60	4	IS
120	-	25	-	40	4	IS
120	-	30	-	21	4	IS
150	-	40	-	32	4	IS
42	40	18	-	23	-	RB
62	60	21	-	33	-	RB
72	70	21	-	33	-	RB
82	80	25	-	40	-	RB
102	100	32	-	54	-	RB
122	120	38	-	46	-	RB

STOP DAMPERS □ CIRCULAR
 NÁRAZNÍKOVÉ PRUŽINY - KRUHOVÉ
 БУФЕРЫ □ КОНИЧЕСКИЕ

Type DS-4

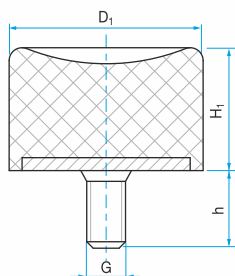

Type DS-5

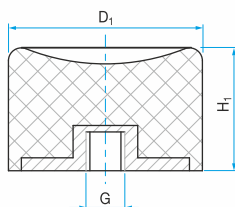

Type KD-4

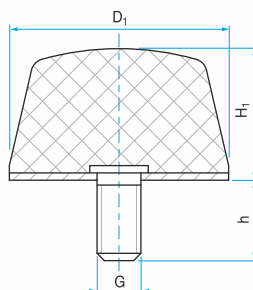

Type KD-5

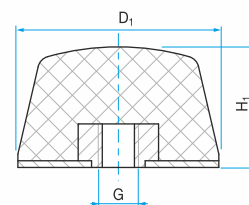

Type KE-4

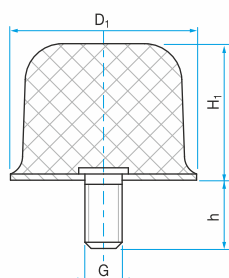

Type KE-5

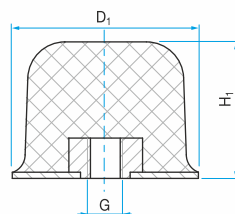

Type KG-4

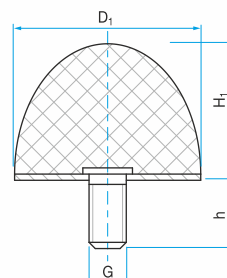

Type KG-5

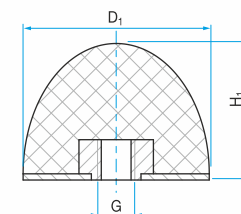

D ₁	D ₂	H ₁	Thread 1 Závit 1 Винт 1 (Gxh)	ShA Шоп А	Shape Tvar Модель	Type Typ Тип
15	-	14	M 4x13	55	-	DS-4
20	-	23,5	M6x18	55	-	DS-4
25	-	18,5	M 6x18	55	-	DS-4
40	-	28	M 8x10	55	-	DS-4
50	-	28	M10x33	55	-	DS-4
70	-	43	M10x28	55	-	DS-4
75	-	37	M12x37	55	-	DS-4
15	-	14	M4	55	-	DS-5
20	-	23,5	M6x18	55	-	DS-5
25	-	18,5	M6	55	-	DS-5
40	-	28	M8	55	-	DS-5
50	-	28	M10	55	-	DS-5
70	-	43	M10	55	-	DS-5
75	-	37	M12	55	-	DS-5
18	-	18	M 6x10	50	77.16	.16
25	-	25	M 6x12	50	78.16	.16
35	-	35	M 8x16	50	76.16	.16
50	-	50	M10x20	50	79.16	.16
70	-	70	M12x24	50	80.16	.16
12	-	12	M 4x10	55	-	KD-4
14	-	6,3	M 4x 4	55	-	KD-4
25	-	12	M 6x18	55	-	KD-4
25	-	14	M 4x10	55	-	KD-4
25	-	17	M 6x18	55	-	KD-4
45	-	21	M 8x46	55	-	KD-4

D ₁	D ₂	H ₁	Thread 1 Závit 1 Винт 1 (Gxh)	ShA Шоп А	Shape Tvar Модель	Type Typ Тип
50	-	18	M10x28	55	-	KD-4
50	-	50	M10x28	55	-	KD-4
125	-	45	M16x45	55	-	KD-4
12	-	12	M4	55	-	KD-5
14	-	6,3	M4	55	-	KD-5
25	-	12	M6	55	-	KD-5
25	-	14	M4	55	-	KD-5
25	-	17	M6	55	-	KD-5
45	-	21	M8	55	-	KD-5
50	-	18	M10	55	-	KD-5
50	-	50	M10	55	-	KD-5
125	-	45	M16	55	-	KD-5
50	-	35	M10x10	55	-	KE-4
50	-	35	M10	55	-	KE-5
25	-	13	M 6x10	55	-	KG-4
25	-	15	M 6x18	55	-	KG-4
30	-	26	M 8x48	55	-	KG-4
25	-	13	M6	55	-	KG-5
25	-	15	M6	55	-	KG-5
30	-	26	M8	55	-	KG-5
38	30	35	M10x27	55	-	KH-D
43	30	35	M10x27	55	-	KH-D
43	30	50	M10x25	55	-	KH-D
38	30	35	M10	55	-	KH-E
43	30	35	M10	55	-	KH-E

Type KH-D

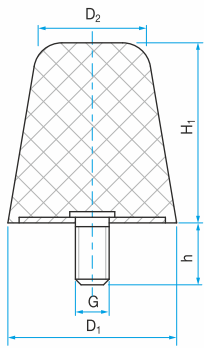

Type KH-E

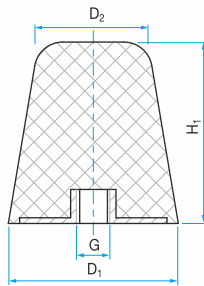

Type KK-4

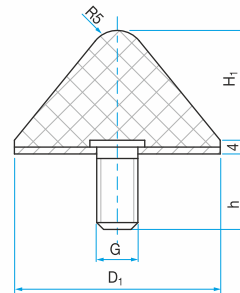

Type KK-5

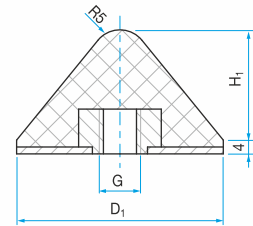

Type KP-D

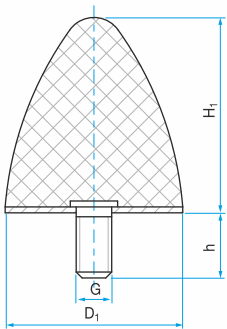

Type KP-E

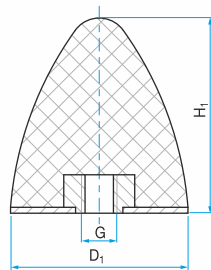

Type .16

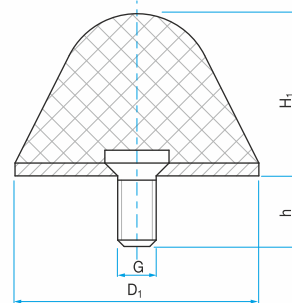

D ₁	D ₂	H ₁	Thread 1 Závit 1 Винт 1 (Gxh)	ShA Шоп А	Shape Tvar Модель	Type Typ Тип
43	30	50	M10	55	-	KH-E
63	57,5	50	M10	55	-	KH-E
24	-	17	M 8x20	55	-	KK-4
25	-	16	M 8x20	55	-	KK-4
40	-	24	M 8x28	55	-	KK-4
50	-	28	M 8x28	55	-	KK-4
50	-	45	M10x35	55	-	KK-4
60	-	45	M10x28	55	-	KK-4
85	-	65	M12x37	55	-	KK-4
24	-	17	M8	55	-	KK-5
25	-	16	M8	55	-	KK-5
40	-	24	M8	55	-	KK-5
50	-	28	M8	55	-	KK-5
50	-	45	M10	55	-	KK-5
60	-	45	M10	55	-	KK-5
85	-	65	M12	55	-	KK-5
10	-	10	M 5x12	55	-	KP-D
20	-	15	M 6x10	55	-	KP-D
20	-	24	M 6x18	55	-	KP-D
25	-	16	M 6x18	55	-	KP-D
25	-	20	M 6x18	55	-	KP-D
30	-	30	M 8x20	55	-	KP-D
30	-	36	M 8x20	55	-	KP-D
35	-	40	M 8x23	55	-	KP-D
50	-	50	M10x28	55	-	KP-D

D ₁	D ₂	H ₁	Thread 1 Závit 1 Винт 1 (Gxh)	ShA Шоп А	Shape Tvar Модель	Type Typ Тип
50	-	61	M 8x28	55	-	KP-D
50	-	67	M10x28	55	-	KP-D
50	-	68	M10x38	55	-	KP-D
70	-	58	M12x32	55	-	KP-D
75	-	89	M12x37	55	-	KP-D
95	-	80	M16x42	55	-	KP-D
118	-	77	M16x41	55	-	KP-D
10	-	10	M 5	55	-	KP-E
20	-	15	M 6	55	-	KP-E
20	-	24	M 6	55	-	KP-E
25	-	16	M 6	55	-	KP-E
25	-	20	M 6	55	-	KP-E
30	-	30	M 8	55	-	KP-E
30	-	36	M 8	55	-	KP-E
35	-	40	M 8	55	-	KP-E
50	-	50	M10	55	-	KP-E
50	-	61	M 8	55	-	KP-E
50	-	67	M 8	55	-	KP-E
50	-	68	M10	55	-	KP-E
70	-	58	M12	55	-	KP-E
75	-	89	M12	55	-	KP-E
95	-	80	M16	55	-	KP-E
118	-	77	M16	55	-	KP-E

CYLINDRICAL VIBRATION DAMPERS NONSTANDARD □ DISC
 VÁLCOVÉ PRUŽINY NESTANDARDNÍ □ KOTOUČOVÉ
 ЦИЛИНДРИЧЕСКИЕ АМОТИФТОРЫ НЕСТАНДАРТНЫЕ □ ДИСКОВЫЕ

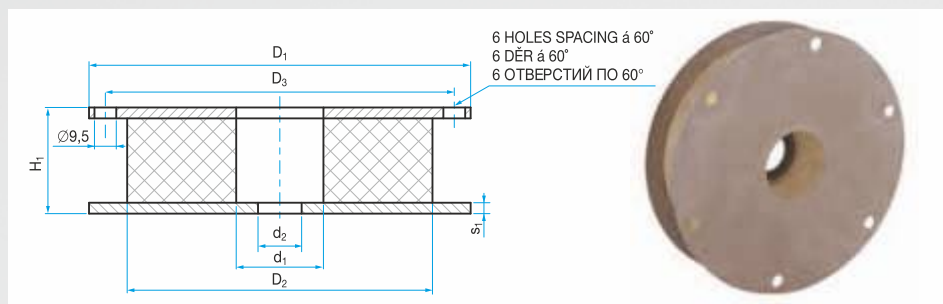

54

D ₁	D ₂	D ₃	d ₁	d ₂	H ₁	s ₁	Shape Tvar Модель	Type Typ Тип
195	150	175	50	30	44	2	17.13	.13
210	175	190	50	30	44	2	18.13	.13
240	200	225	90	35	46	2	19.13	.13
254	220	-	90	35	46	2	20.13	.13
275	235	255	75	35	48	3	21.13	.13
315	270	295	75	40	48	3	23.13	.13

Note:

Metal parts for shapes 20.13, 21.13, 23.13 are supplied by the customer according to the producer's drawing. Vibration dampers are manufactured out of a rubber grade with hardness 50 ShA.

Poznámka:

Kovové díly pro tvary 20.13, 21.13, 23.13 si dodává zákazník dle výkresu výrobce. Pružiny se vyrábějí z pryže o tvrdosti 50 ShA.

замечка:

Металлические части для моделей 20.13, 21.13, 23.13 подает заказчик по чертежам изготовителя. Цилиндрические амортизаторы изготавливаются из резины твердостью 50 Шор А.

STOP DAMPERS \sqcup PRISMATIC NÁRAZNÍKOVÉ PRUŽINY \sqcup HRANOLOVÉ БУФЕРЫ \sqcup ПРИФМАТИЧЕСКИЕ

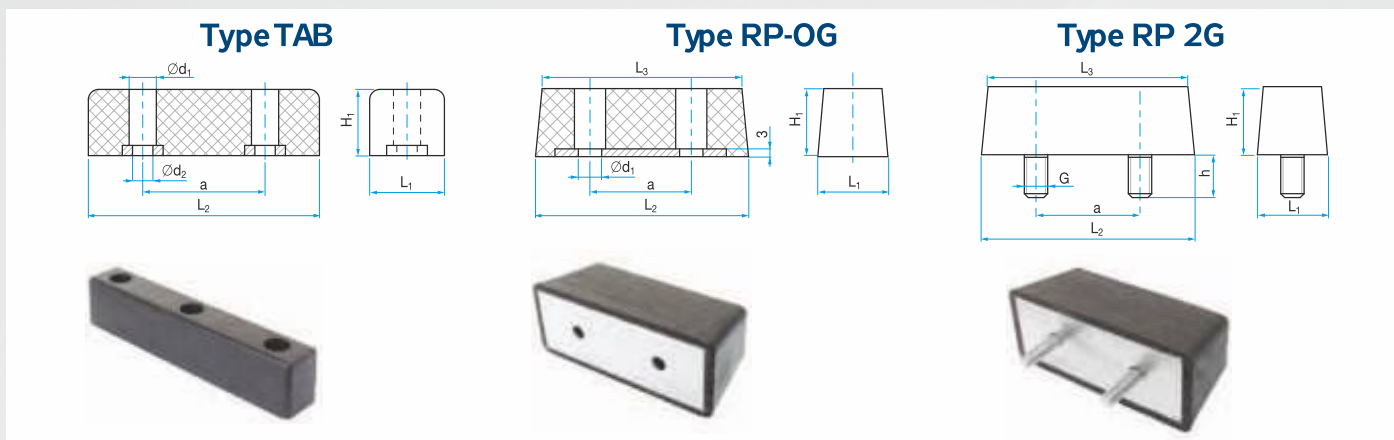

L ₁	L ₂	L ₃	H ₁	d ₁	d ₂	a	Number of holes Počet otvorů Число отверстий	Thread Závit Винт (Gxh)	Type Typ Тип
40	125	-	15	19,7	8	60	2	-	TAB
40	125	-	40	19,8	8	60	2	-	TAB
43	125	-	50	20,3	8	60	2	-	TAB
43	125	-	70	19,8	8	60	2	-	TAB
52	200	-	60	26	10,5	120	2	-	TAB
52	200	-	80	26	10,5	120	2	-	TAB
52	300	-	60	26	10,5	115	3	-	TAB
52	300	-	80	26	10,5	115	3	-	TAB
52	400	-	60	26	10,5	165	3	-	TAB
52	400	-	80	26	10,5	165	3	-	TAB
60	530	-	35	26	12,5	157	4	-	TAB
60	150	136	60	11	-	70	-	M10x32	RP-2G
100	200	168	100	13	-	90	-	M12x36	RP-2G
60	150	136	60	11	-	70	2	-	RP-OG
100	200	168	100	13	-	90	2	-	RP-OG

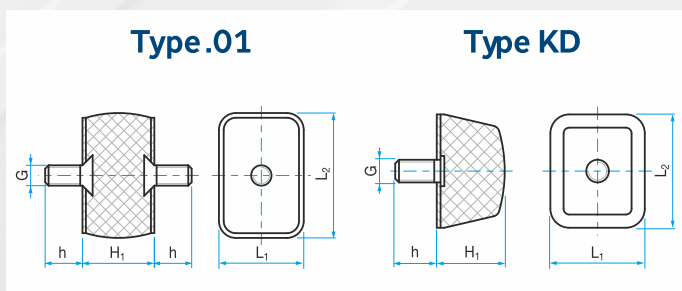

L ₁	L ₂	H ₁	Thread 1 Závit 1 Винт 1 (Gxh)	ShA Шоп А	Shape Tvar Модель	Type Typ Тип
40	60	35	M10x18	50	07.01	.01
60	90	38	M12x23	60	14.01	.01
50	50	20	M10x28	55	-	KD
80	80	27	M12x37	55	-	KD

STOP DAMPERS 4 GP
 NÁRAZNÍKOVÉ PRUŽINY 4 GP
 БУФЕРЫ 4 GP

Type GP-1G

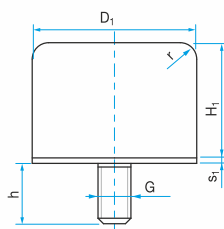

Type GP-2G

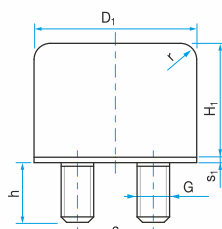

Type GP-1I

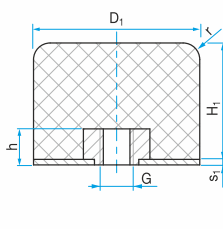

Type GP-QP

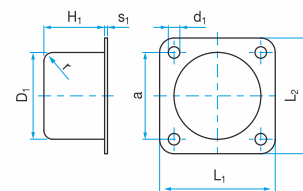

56

D ₁	H ₁	L ₁	L ₂	d ₁	a	Number of holes Počet otvorů Число отверстий (Gxh)	r	s ₁	Type Typ Тип
40	32	-	-	-	-	M 8x23	8	2	GP-1G
40	32	-	-	-	-	M 8x 8	8	2	GP-1I
40	32	50	50	5,5	40	-	8	2	GP-QP
50	40	-	-	-	-	M10x28	10	2	GP-1G
50	40	-	-	-	-	M10x10	10	2	GP-1I
50	40	63	63	6,5	50	-	10	3	GP-QP
63	50	-	-	-	-	M10x28	12,5	3	GP-1G
63	50	-	-	-	-	M10x10	12,5	3	GP-1I
63	50	80	80	6,5	63	-	12,5	4	GP-QP
80	63	-	-	-	-	M12x37	18	3	GP-1G
80	63	-	-	-	-	M12x12	18	3	GP-1I
80	63	100	100	9	80	-	18	5	GP-QP
100	80	-	-	-	-	M12x36	20	4	GP-1G
100	80	-	-	-	-	M12x12	20	4	GP-1I
100	80	-	-	-	50	M12x36	20	4	GP-2G
100	80	125	125	9	100	-	20	6	GP-QP
125	100	-	-	-	-	M16x36	25	4	GP-1G
125	100	-	-	-	-	M16x16	25	4	GP-1I
125	100	-	-	-	63	M16x36	25	4	GP-2G
125	100	160	160	11	125	-	25	6	GP-QP
160	125	-	-	-	-	M16x44	32	6	GP-1G
160	125	-	-	-	-	M16x16	32	6	GP-1I
160	125	-	-	-	80	M16x44	32	6	GP-2G
160	125	200	200	11	160	-	32	8	GP-QP
200	160	-	-	-	-	M20x44	40	6	GP-1G
200	160	-	-	-	-	M20x18	40	6	GP-1I
200	160	-	-	-	100	M20x44	40	6	GP-2G
200	160	250	250	13	200	-	40	8	GP-QP

COVER DAMPERS
 POUZDROVÉ PRUŽINY
 ВТУЛОЧНЫЕ ФОРТИФТОРЫ

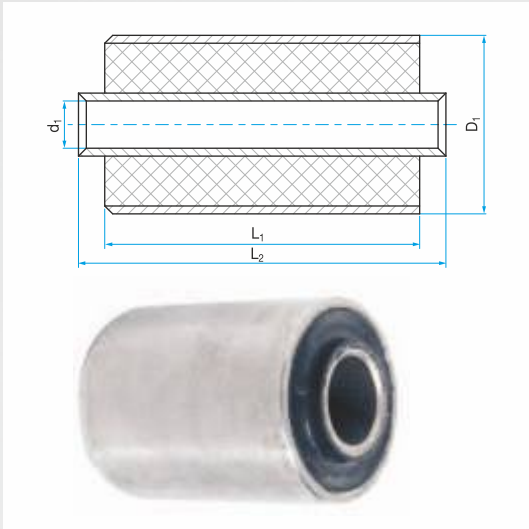

d ₁	D ₁	L ₁	L ₂	Shape Tvar Модель
8,5	26	25	25	-
10	22	24	20	-
10	25	20	25	-
12	22	25	28	-
13	30	40	40	-
14	27	40	48	-
14	30	25	28	-
14	30	45	50	06.21
14	30	67	76	-
15,5	55	30	16	-
16	32	50	54	-
20	45	60	63	-
25	40	20	20	-
25	40	30	30	-
25	50	30	34	-
25	50	65	68	-
25	50	80	85	-
30	60	60	68	-
36	62	65	71	-
38	64	80	88	-

RUBBER-METAL RAILS
 HRANOLOVÁ LŮŽKA
 РЕФИНО-МЕТАЛЛИЧЕСКИЕ ПРИФМЫ

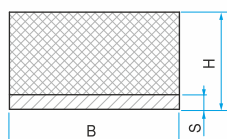

L = max. 2000 mm

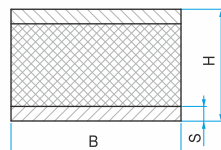

L = max. 2000 mm



58

GS-M1

H	B
10	30
20	25
20	30
25	25
25	30
30	20
30	30
35	15
35	50
40	20
40	30
40	35
40	40
40	45
40	50
50	10
50	15
50	20
50	25
50	30
50	35
50	40
50	45

L = max. 2000 mm
 s = 5, 10 nebo 15 mm

H	B
50	50
50	55
50	60
50	70
60	20
60	30
60	35
60	40
60	45
60	50
60	55
60	60
60	70
120	60
120	70
120	80
150	30
150	40
150	50
150	60
150	70
150	75

GS-M2

H	B
60	80
70	30
70	40
70	45
70	50
70	60
70	70
70	80
70	55
70	60
75	40
75	55
80	20
80	40
80	45
80	60
80	70
80	80
90	45
100	12
100	20
100	30

L = max. 2000 mm
 s = 5, 10 nebo 15 mm

H	B
100	75
100	80
100	90
100	100
110	40
120	45
120	50
150	80
150	90
150	100
200	30
200	60
200	70
200	80
200	100

HEAVY DUTY DAMPERS VYSOKOZÁTĚŽOVÉ SILENTBLOKY БУФЕРИ ДЛЯ ВЫСОКОЙ НАГРУЗКИ

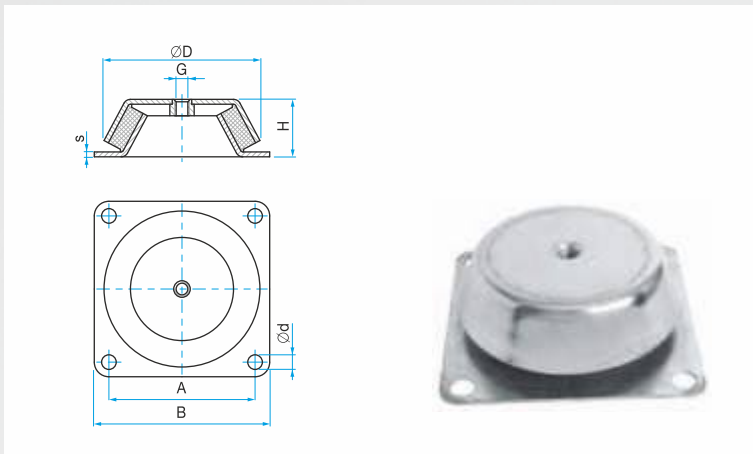

QMF

D	H	A	B	S	G	d	Load N	ShA
160	60	175	145	3	M 16	12,5	8000	60
177	63	180	150	3	M 20	13,5	14000	60



VIBR M

D	E	A	K	H	h	d	G	ShA
18	43	50	64	20	7	7,0	M 6	55
33	56	66	85	25	11	8,0	M 8	55
45	76	92	114	35	14	10,0	M 10	55
53	96	110	136	40	15	11,5	M 10	55
58	101	124	151	45	13	11,5	M 10	55
70	-	120	150	63	18	14,5	M 12	55
100	-	160	200	85	25	14,5	M 16	55
186	-	250	310	160	43	18,0	M 24	55

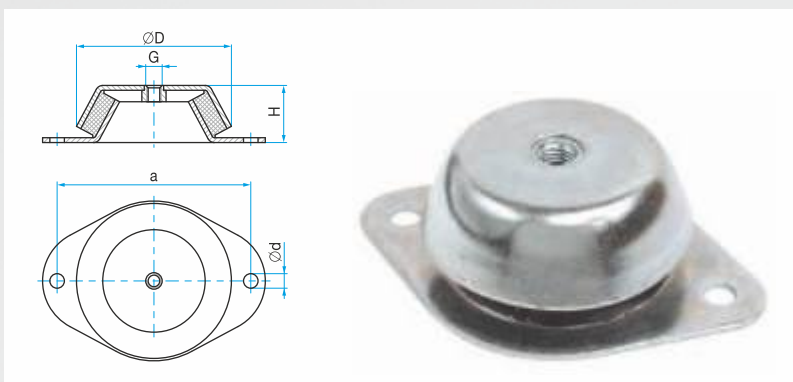

GMF

D	H	a	d	G	Load N	ShA
48	23	68	6,2	M8	1000	60
62	30	85	8,2	M10	2000	60
92	45	110	10,2	M12	3000	60
101	38	175	14,0	M12	4000	60
106	38	140	12,4	M12	4000	60
160	60	200	16,2	M16	10000	60

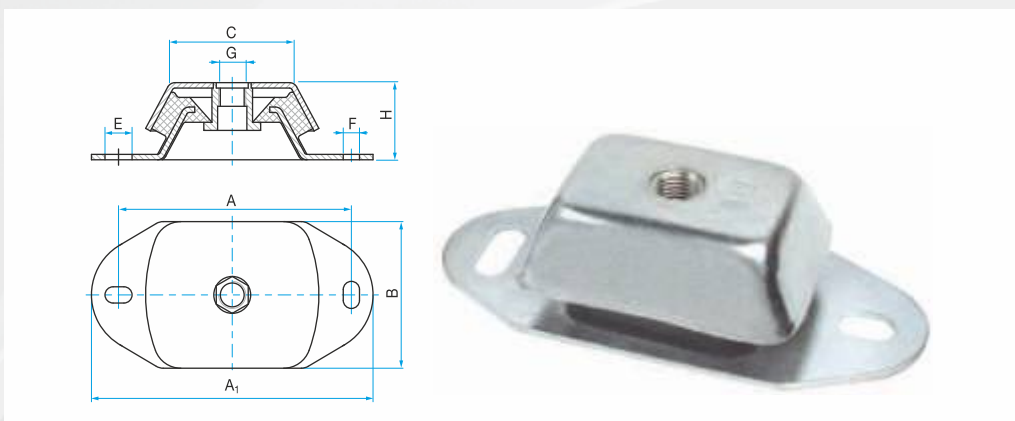

MF

A	A ₁	B	C	E	F	G	H	ShA
182	230	112	80	25x18	18x33	M20	73	60
140	183	75	75	20x13	13x30	M16	50	60
100	120	60	60	11x14	11x14	M10	40	60

POLYURETHANE BUFFERS
 POLYURETANOVÉ SILENTBLOKY
 ПОЛИУРЕТАНОВЫЕ АМОТИФТОРЫ

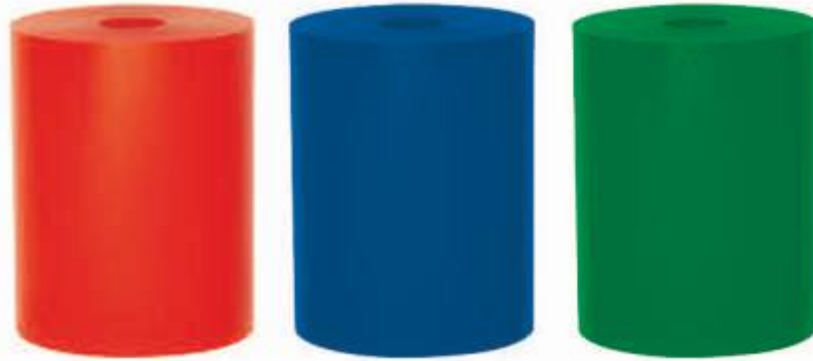
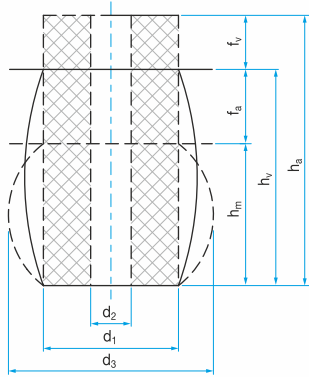

PU 80 Shore A

Barva červená/Colour red/Цвет красный

PU 90 Shore A

Barva modrá/Colour blue/Цвет синий

PU 95 Shore A

Barva zelená/Colour green/Цвет зеленый

d ₁	d ₂	h ₀	h _v	f _a	tlak [kPa]	d ₃	h ₀	h _v	f _a	tlak [kPa]	d ₃	h ₀	h _v	f _a	tlak [kPa]	d ₃
16	6,5	12,5	11	3	115	~21	12,5	11,5	2	158	~20	12,5	11	1,5	192	~19,5
		16	14,5	4	110		16	14,5	3	153		16	14,5	2	188	
		20	18	5	106		20	18	4	150		20	18	3	185	
		25	22,5	6	104		25	22,5	5	148		25	22,5	4	182	
20	8,5	16	14,5	4	175	~28	16	14,5	3	235	~27	16	14,5	2	290	~25
		20	18	5	170		20	18	4	230		20	18	3	285	
		25	22,5	6	165		25	22,5	5	228		25	22,5	4	282	
		32	28,5	7,5	162		32	28,5	6	226		32	28,5	4,5	280	
25	8,5	20	18	5	280	~35	20	18	4	398	~32	20	18	3	490	~30
		25	22,5	6	275		25	22,5	5	390		25	22,5	4	480	
		32	28,5	7,5	270		32	28,5	6	386		32	28,5	4,5	475	
		40	36	10	268		40	36	8	382		40	36	6	470	
32	13,5	32	28,5	7,5	440	~42	32	28,5	6	595	~39	32	28,5	4,5	730	~38
		40	36	10	430		40	36	8	585		40	36	6	718	
		50	45	12,5	425		50	45	10	580		50	45	7,5	708	
		63	56	15	420		63	56	12	757		63	56	9	700	
40	13,5	32	28,5	7,5	745	~52	32	28,5	6	1020	~49	32	28,5	4,5	1250	~46
		40	36	10	735		40	36	8	1000		40	36	6	1230	
		50	45	12,5	730		50	45	10	995		50	45	7,5	1225	
		63	56	15	725		63	56	12	990		63	56	9	1215	
50	17	80	72	20	720		80	72	16	985		80	72	12	1200	
		32	28,5	7,5	1200	~66	32	28,5	6	1600	~62	32	28,5	4,5	2010	~59
		40	36	10	1170		40	36	8	1575		40	36	6	1960	
		50	45	12,5	1150		50	45	10	1550		50	45	7,5	1920	
		63	56	15	1130		63	56	12	1530		63	56	9	1900	
		80	72	20	1120		80	72	16	1515		80	72	12	1880	
		100	90	25	1110		100	90	20	1500		100	90	15	1860	

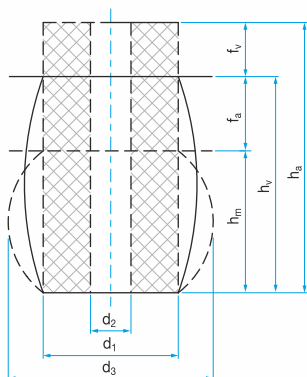

PU 80 Shore A

Barva červená/Colour red/Цвет красный

PU 90 Shore A

Barva modrá/Colour blue/Цвет синий

PU 95 Shore A

Barva zelená/Colour green/Цвет зеленый

d ₁	d ₂	h ₀	h _v	f _a	tlak [kPa]	d ₃	h ₀	h _v	f _a	tlak [kPa]	d ₃	h ₀	h _v	f _a	tlak [kPa]	d ₃
63	17	32	28,5	7,5	2200	~80	32	28,5	6	2800	~79	32	28,5	4,5	3450	~75
		40	36	10	1200		40	36	8	2720		40	36	6	3360	
		50	45	12,5	2000		50	45	10	2650		50	45	7,5	3280	
		63	56	15	1930		63	56	12	2600		63	56	9	3200	
		80	72	20	1890		80	72	16	2550		80	72	12	3150	
		100	90	25	1850		100	90	20	2500		100	90	15	3110	
80	21	32	28,5	7,5	3600	~105	32	28,5	6	4970	~102	32	28,5	4,5	6000	~98
		40	36	10	3450		40	36	8	4660		40	36	6	5750	
		50	45	12,5	3280		50	45	10	4520		50	45	7,5	5540	
		63	56	15	3150		63	56	12	4340		63	56	9	5360	
		80	72	20	3100		80	72	16	4200		80	72	12	5200	
		100	90	25	3040		100	90	20	4130		100	90	15	5130	
100	21	125	112	30	2980	~127	125	112	24	4050	~125	125	112	18	5060	~121
		32	28,5	7,5	6000		32	28,5	6	8050		32	28,5	4,5	10200	
		40	36	10	5750		40	36	8	7740		40	36	6	9700	
		50	45	12,5	5520		50	45	10	7420		50	45	7,5	9220	
		63	56	15	5320		63	56	12	7140		63	56	9	8820	
		80	72	20	5120		80	72	16	6900		80	72	12	8570	
125	27	32	28,5	7,5	10000	~155	32	28,5	6	12450	~150	32	28,5	4,5	17200	~105
		40	36	10	9580		40	36	8	12000		40	36	6	16200	
		50	45	12,5	8800		50	45	10	11550		50	45	7,5	15100	
		63	56	15	8520		63	56	12	11150		63	56	9	14300	
		80	72	20	8060		80	72	16	10700		80	72	12	13600	
		100	90	25	7800		100	90	20	10300		100	90	15	13000	
125	27	125	112	30	7700	~155	125	112	24	10050	~150	125	112	18	12900	~105
		160	144	40	7580		160	144	32	9850		160	144	24	12800	



Rubena

Servisní sklad
Českých bratří 338
547 36 Náchod
Czech Republic
Tel.: +420 491 447 558
+420 491 447 559
+420 491 447 560
+420 491 447 565
Fax: +420 491 447 569

e-mail: sklad@rubena.cz
For more information about visit:
www.rubena.eu,
B2B E shop: e-shop.rubena.cz

